

A9 • Performing number magic

Mathematical goals

To enable learners to:

- develop an understanding of linear expressions and equations;
- make simple conjectures and generalisations;
- add expressions, 'collecting like terms';
- use the distributive law of multiplication over addition in simple situations;
- develop an awareness that algebra may be used to prove generalisations in number situations.

Starting points

It is helpful, but not essential, if learners have previously encountered the idea of using letters to represent variables and already have some experience of simplifying expressions by 'collecting like terms'. These ideas are developed during the session.

The activity begins by inviting learners to look at some simple number magic. This is best done using the computer software *Number magic* that is provided on the DVD, but it can also be done using paper copies of the tricks.

The activity involves the following steps:

- learners familiarise themselves with a trick;
- learners try to work out how the trick is done, using algebra;
- learners try to improve the trick, making it more impressive.

Thus, this session meets the needs of all learners by allowing them to create tricks at different levels of difficulty.

Materials required

For each small group of learners you will need:

- calculator;
- computer running the software *Number magic*;

or at least one of:

- Sheets 1 to 5 – *Trick 1 to 5*

(with OHTs of these).

Time needed

From 1 to 2 hours, depending on the number of tricks used with each group of learners.

Suggested approach **Beginning the session**

Begin the session by performing a 'lightning calculation' trick for the whole group. For example:

$$\begin{array}{r}
 14 \\
 8 \\
 22 \\
 30 \\
 52 \\
 82 \\
 134 \\
 216 \\
 350 \\
 \underline{566} \\
 \text{Total: } 1474
 \end{array}$$

Ask someone to suggest two whole numbers. Write these numbers one above the other at the top of the board. In the example, the two numbers are 14 and 8.

Now ask someone to write the sum of these two numbers underneath. They should then repeatedly add the last two numbers in the list and write the answer underneath. Continue in this way until 10 numbers are listed. Now challenge the group to add all ten numbers together.

As soon as the seventh number has been listed (in this case it is 134), you mentally multiply this number by 11 and write the answer (in this case 1474) on a large sheet of paper and, very obviously, stick it to the board so that the answer is hidden.

When learners arrive at an answer, turn over your sheet and display the answer. How did you know this before the list of numbers was complete?

Now explain how the trick is done, using algebra.

1	x
2	y
3	$x + y$
4	$x + 2y$
5	$2x + 3y$
6	$3x + 5y$
7	$5x + 8y$
8	$8x + 13y$
9	$13x + 21y$
10	$21x + 34y$
Total	$55x + 88y$

Ask learners to write x and y instead of the two starting numbers and get them to produce the rest of the table.

Emphasise why we can 'collect like terms'.

Finally, ask the group if they can spot any connection between the seventh term and the final total. Hopefully, they will see that $11(5x + 8y) = 55x + 88y$. This proves that the total will always be 11 times the 7th term.

Spend some time on the idea that algebra reveals the structure of a trick and proves that results work for all possible numbers.

This task involves two variables, x and y . The activities in this session start by requiring the use of only one variable, but they may be extended into two.

Introduce the main activity of the session using OHTs of the tricks on Sheets 1–5, or using an interactive whiteboard or data projector if you decide to use the computer programs.

Learners may enjoy working in pairs at a computer using the software provided. Alternatively, you could simply present the tricks on separate cards and ask learners to choose one or two to explore. Allow them to use calculators if they wish, as arithmetic is not our central concern here.

Explain to learners that, for each trick, they should:

- explore the trick, trying different numbers;
- work out how the trick is done. This usually involves spotting a connection between a starting number(s) and a finishing number. Algebra will be helpful here: “let the starting number be n and try to find an expression for the finishing number”;
- improve the trick in some way.

Working in groups

Ask learners to work in pairs and give each pair one of the tricks.

Trick 1: Consecutive sum

In *Consecutive sum* learners vary the starting numbers and make conjectures about the totals produced. They may decide, for example that the final total is always a multiple of 5. Some may reason as follows:

You add on a number one more, then you add a number two more, then a three more, then four more. That makes ten more altogether. So you add ten to five times the number.

Encourage learners to show this more formally, by writing n for the first number, $n + 1$ for the second and so on. The final total obtained is $5n + 10$ (or $5(n + 2)$). A quick way to predict the total from any starting number is to multiply by 5 and then add 10, or add 2 and then multiply by 5. Learners may be encouraged to develop this situation into a more complex number trick. It could be made more impressive by having more addends, for example.

Trick 2: Pyramid

In *Pyramid*, if the bottom left hand number is called x , then

- the bottom row is $x, x + 1, x + 2, x + 3, x + 4$;
- the second row is $3x + 3, 3x + 6, 3x + 9$;
- the top row is $9x + 18 = 9(x + 2)$.

So the short cut is simply to add 2 to the bottom left hand number and then multiply by 9 (or multiply by 9 and add 18). Learners may like to try creating larger Pyramids.

Trick 3: Routes

This simple trick uses the distributive law. The software allows learners to change the number in box A. If the number in box A is called x , then the number in box B is called $3x + 5$ and the number in box C is $3(x + 5) = 3x + 15$. This immediately shows that the number in box C is always 10 more than the number in box B. Learners should be encouraged to test this using large numbers and

decimals in box A. Learners may like to explore the effect of changing the numbers along the routes.

Trick 4: Adding pairs

By experiment, learners may conjecture that, when you increase the first number by 1, the final number is increased by 3. They may draw up a table of results and look for patterns expressing these in algebra. Encourage them to prove their conjectures using algebra.

If the first number is called n , then successive numbers may be written: $n, 10, n + 10, n + 20, 2n + 30, 3n + 50$. The final number may therefore be obtained by multiplying the first number by 3 and adding 50. Learners may try improving the trick by generating longer sequences, or by changing the second number (10) to something different.

Trick 5: Calendar

In the *Calendar* software, learners drag the window to cover different sets of numbers.

n	$n + 1$	$n + 2$
$n + 7$	$n + 8$	$n + 9$
$n + 14$	$n + 15$	$n + 16$

In order to explain the trick, encourage learners to choose one of the numbers to be represented by, say, n and then represent the remaining numbers in the window in terms of n .

Thus, if the top left hand corner of the window is n , then the sum of eight numbers in the window border is $8n + 64$. The number in the centre of the window is $n + 8$.

$n - 8$	$n - 7$	$n - 6$
$n - 1$	n	$n + 1$
$n + 6$	$n + 7$	$n + 8$

Since $8(n + 8) = 8n + 64$, the sum of numbers in the window is $8 \times$ the centre number. The trick is done by mentally dividing the total by 8.

Learners may like to try substituting n for different positions in the window. For example, if the centre number is called n , the surrounding numbers simply add to $8n$. Learners may like to try using different shaped windows on other grids.

Reviewing and extending learning

Ask learners to perform each of the magic tricks for the others in the group. They should then explain their analysis and show any improvements they have made.

You could ask learners to use algebra to analyse a statement such as the following:

The sum of n consecutive numbers is divisible by n .
Is this always, sometimes or never true?
Can you say when it is true and when it is not?

What learners might do next

A9 Sheet 1 – Trick 1

Consecutive sum

In this sum you add consecutive numbers.

The audience changes the top number and tells you what it is.

You immediately give the total.

How is the trick done?

Can you make the trick more impressive?

	23
	24
	25
	26
+	27
Total	125

A9 Sheet 2 – Trick 2

Pyramid

		63		
	18	21	24	
5	6	7	8	9

The bottom row of this pyramid contains consecutive numbers.

Each other number is found by adding the three numbers beneath it.

The audience changes the bottom left hand number and tells you what it is.

You immediately say what the top number is.

How is the trick done?

Try to make the trick more impressive.

A9 Sheet 3 – Trick 3

Routes

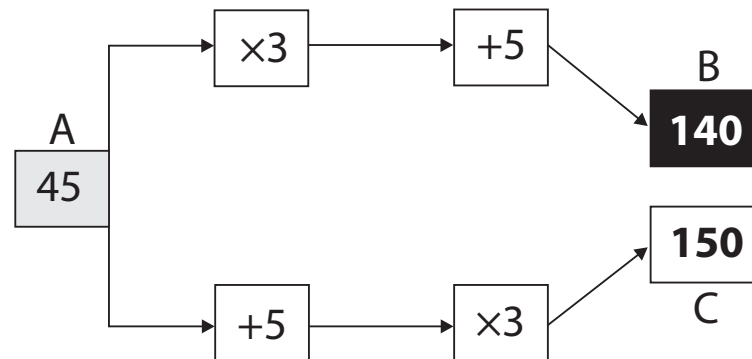

You are blindfolded.

The audience changes the number in box A.

The audience tells you the number in box B.

You immediately say the number in box C.

How is the trick done?

Can you make the trick more impressive?

(You can change the $\times 3$ and $+5$ to other numbers if you want.)

A9 Sheet 4 – Trick 4

Adding pairs

5	10	15	25	40	65
----------	-----------	----	----	----	-----------

Each number is the sum of the two previous numbers.

The audience changes the numbers in the two left hand boxes.

You immediately say the number in the right hand box.

How is the trick done?

Try to make the trick more impressive.

A9 Sheet 5 – Trick 5

Calendar

Mon	Tues	Wed	Thur	Fri	Sat	Sun
1	2	3	4	5	6	7
8	9	10	11	12	13	14
15	16	17	18	19	20	21
22	23	24	25	26	27	28
29	30	31				

The audience moves the window to cover 8 dates.

They add the 8 dates together and tell you the total.

You immediately tell them the number in the middle of the window.

How is the trick done?

Try to make the trick more impressive.

Mon	Tues	Wed	Thur	Fri	Sat	Sun
1	2	3	4	5	6	7
8	9	10	11	12	13	14
15	16	17	18	19	20	21
22	23	24	25	26	27	28
29	30	31				