

Write your name here

Surname

Correction

Other names

M. Semar

Centre Number

--	--	--	--	--

Candidate Number

--	--	--	--	--

Edexcel GCSE

Mathematics A

Paper 1 (Non-Calculator)

Higher Tier

Monday 11 June 2012 – Afternoon

Time: 1 hour 45 minutes

Paper Reference

1MA0/1H

You must have: Ruler graduated in centimetres and millimetres, protractor, pair of compasses, pen, HB pencil, eraser. Tracing paper may be used.

Total Marks



Instructions

- Use **black** ink or ball-point pen.
- **Fill in the boxes** at the top of this page with your name, centre number and candidate number.
- Answer **all** questions.
- Answer the questions in the spaces provided
– *there may be more space than you need.*
- **Calculators must not be used.**

Information

- The total mark for this paper is 100
- The marks for **each** question are shown in brackets
– *use this as a guide as to how much time to spend on each question.*
- Questions labelled with an **asterisk** (*) are ones where the quality of your written communication will be assessed.

Advice

- Read each question carefully before you start to answer it.
- Keep an eye on the time.
- Try to answer every question.
- Check your answers if you have time at the end.

Turn over 

P40645A

©2012 Pearson Education Ltd.

6/6/7/3/

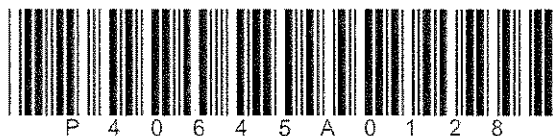

P 4 0 6 4 5 A 0 1 2 8

PEARSON

GCSE Mathematics 1MA0

Formulae: Higher Tier

You must not write on this formulae page.
Anything you write on this formulae page will gain NO credit.

Volume of prism = area of cross section \times length

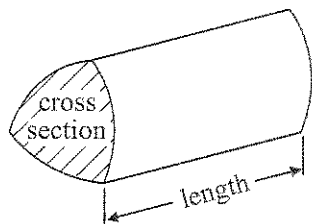

Area of trapezium = $\frac{1}{2} (a + b)h$

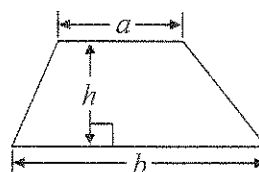

Volume of sphere = $\frac{4}{3} \pi r^3$

Surface area of sphere = $4\pi r^2$

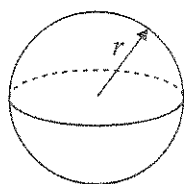

Volume of cone = $\frac{1}{3} \pi r^2 h$

Curved surface area of cone = $\pi r l$

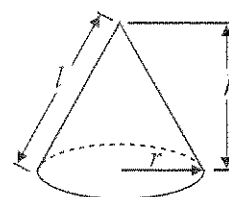

In any triangle ABC

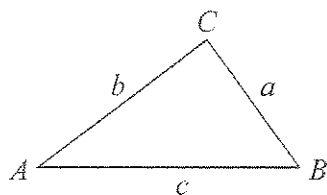

The Quadratic Equation

The solutions of $ax^2 + bx + c = 0$
where $a \neq 0$, are given by

$$x = \frac{-b \pm \sqrt{b^2 - 4ac}}{2a}$$

Sine Rule $\frac{a}{\sin A} = \frac{b}{\sin B} = \frac{c}{\sin C}$

Cosine Rule $a^2 = b^2 + c^2 - 2bc \cos A$

Area of triangle = $\frac{1}{2} ab \sin C$



Answer ALL questions.

Write your answers in the spaces provided.

You must write down all stages in your working.

You must NOT use a calculator.

- 1 Sam wants to find out the types of film people like best.

He is going to ask whether they like comedy films or action films or science fiction films or musicals best.

- (a) Design a suitable table for a data collection sheet he could use to collect this information.

Type of films	Tally	Frequency
• Comedy		
• Action		
• Science fiction		

(2)

Sam collects his data by asking 10 students in his class at school.
This might **not** be a good way to find out the types of film people like best.

- (b) Give **one** reason why.

sample too small

(1)

(Total for Question 1 is 3 marks)



2 The diagram shows a patio in the shape of a rectangle.

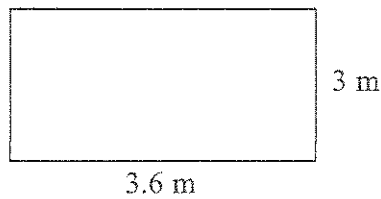

Diagram NOT
accurately drawn

The patio is 3.6 m long and 3 m wide.

Matthew is going to cover the patio with paving slabs.
Each paving slab is a square of side 60 cm.

Matthew buys 32 of the paving slabs.

(a) Does Matthew buy enough paving slabs to cover the patio?
You must show all your working.

$$\begin{aligned} \text{Area of 32 slabs} &= 32 \times 60 \times 60 = 115200 \text{ cm}^2 \\ \text{Area of Patio} &= 3.6 \times 3 = 10.8 \text{ m}^2 \quad (1 \text{ m}^2 = 10^4 \text{ cm}^2) \\ &= 10.8 \times 100 \times 100 \text{ cm}^2 = 108000 \text{ cm}^2 \\ &115200 \text{ bigger than } 108000 \end{aligned}$$

yes -

(3)

The paving slabs cost £8.63 each.

(b) Work out the total cost of the 32 paving slabs.

$$8.63 \times 32 = 276.16$$

$$\begin{array}{r} 863 \\ x 32 \\ \hline 1726 \\ 2589 \\ \hline 27616 \end{array}$$

£ 276.16

(3)

(Total for Question 2 is 6 marks)



- *3 Bill uses his van to deliver parcels.
 For each parcel Bill delivers there is a fixed charge plus £1.00 for each mile.
 You can use the graph to find the total cost of having a parcel delivered by Bill.

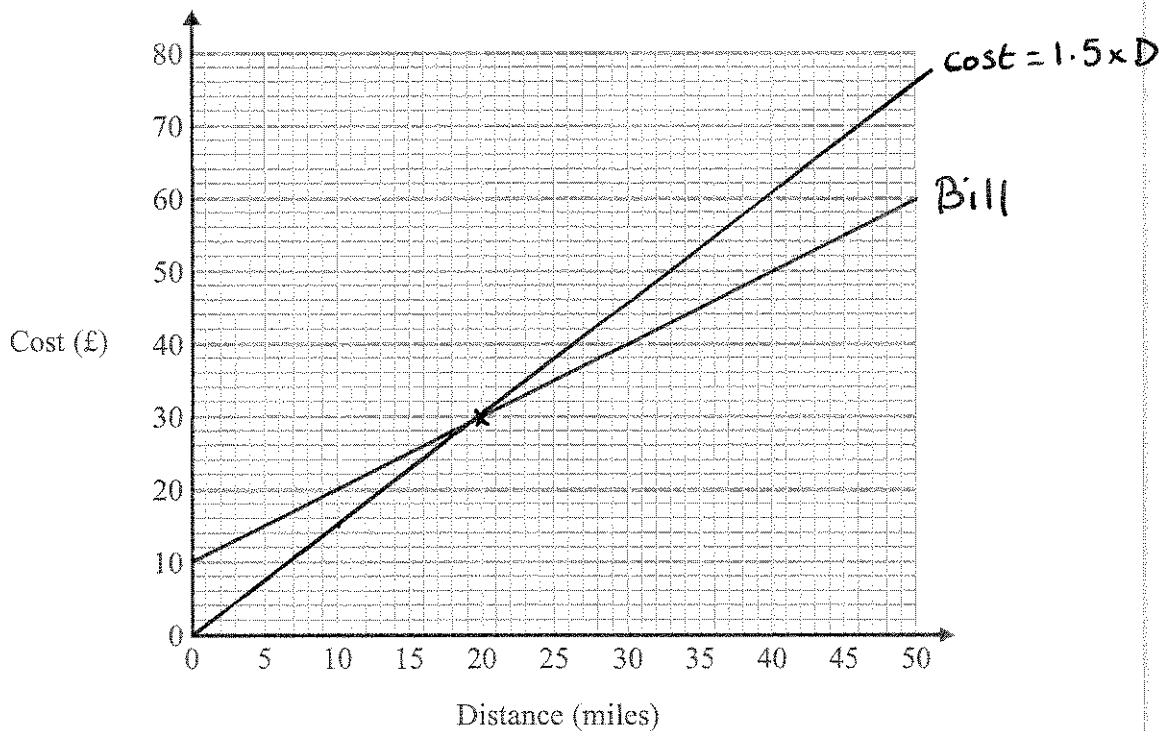

- (a) How much is the fixed charge?

£ 10 (1)

Ed uses a van to deliver parcels.
 For each parcel Ed delivers it costs £1.50 for each mile.
 There is no fixed charge.

$\rightarrow y = 1.5x$

- (b) Compare the cost of having a parcel delivered by Bill with the cost of having a parcel delivered by Ed.

$Cost = 1.5 \times D$

Ed is cheaper up to 20 miles.

Bill is cheaper for more than 20 miles.

(3)

(Total for Question 3 is 4 marks)

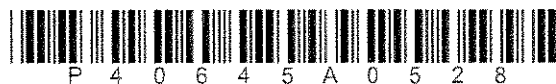

4 Here are the speeds, in miles per hour, of 16 cars.

<u>31</u>	<u>52</u>	<u>43</u>	<u>49</u>	<u>36</u>	<u>35</u>	<u>33</u>	<u>29</u>
<u>54</u>	<u>43</u>	<u>44</u>	<u>46</u>	42	<u>39</u>	55	<u>48</u>

Draw an ordered stem and leaf diagram for these speeds.

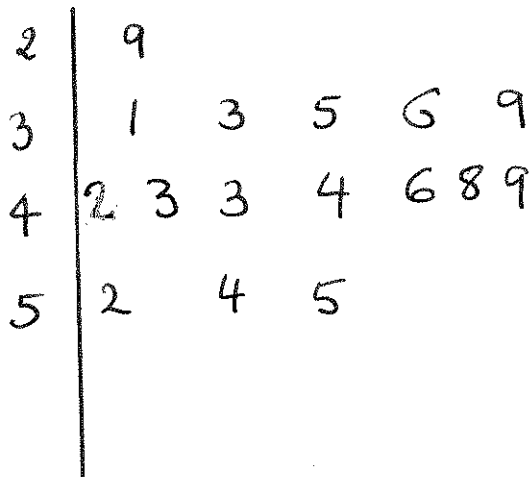

Key 5|2 = 52 mph .

(Total for Question 4 is 3 marks)



5



You can work out the amount of medicine, c ml, to give to a child by using the formula

$$c = \frac{ma}{150}$$

m is the age of the child, in months.

a is an adult dose, in ml.

A child is 30 months old.

An adult's dose is 40 ml.

Work out the amount of medicine you can give to the child.

$$c = \frac{30 \times 40}{150}$$

$$c = \frac{40}{5} = 8$$

..... 8 ml

(Total for Question 5 is 2 marks)

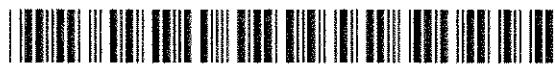

P 4 0 6 4 5 A 0 7 2 8

7

Turn over ▶

6 Here are the ingredients needed to make 12 shortcakes.

Shortcakes
Makes 12 shortcakes

50 g of sugar
200 g of butter
200 g of flour
10 m/ of milk

Liz makes some shortcakes.
She uses 25 m/ of milk.

(a) How many shortcakes does Liz make?

5 cakes	12 cakes	24 cakes	
↓	↓	↓	so 25ml → 30
5ml	10ml	20ml	
			<u>30 cakes</u>
			(2)

Robert has

- 500 g of sugar
- 1000 g of butter
- 1000 g of flour
- 500 m/ of milk

(b) Work out the greatest number of shortcakes Robert can make.

$$\begin{aligned} 500 &\div 50 = 10 \\ 1000 &\div 200 = 5 \\ 1000 &\div 200 = 5 \\ 500 &\div 10 = 50 \\ \underline{5} &\times 12 = 60 \end{aligned}$$

60 cakes
(2)

(Total for Question 6 is 4 marks)



- 7 Buses to Acton leave a bus station every 24 minutes.
Buses to Barton leave the same bus station every 20 minutes.

A bus to Acton and a bus to Barton both leave the bus station at 9 00 am.

When will a bus to Acton and a bus to Barton next leave the bus station at the same time?

9 ; 9.24 ; 9.48 ; 10.12 ; 10.36 ; 11.00 ; 11.24

9 ; 9.20 ; 9.40 ; 10.00 ; 10.20 ; 10.40 ; 11.00 ; 11.20

11 am

(Total for Question 7 is 3 marks)

- 8 (a) Expand $3(2y - 5)$

$$6y - 15$$

$$6y - 15$$

(1)

- (b) Factorise completely $8x^2 + 4xy$

$$2 \times 4 \times x \times x + 4 \times x \times y$$

$$4x(2x + y)$$

$$4x(2x + y)$$

(2)

- (c) Make h the subject of the formula

$$t = \frac{gh}{10}$$

$$10t = \frac{gh}{10} \times 10$$

$$10t = gh$$

$$h = 10 \frac{t}{g}$$

$$h = 10 \frac{t}{g}$$

(2)

(Total for Question 8 is 5 marks)



9

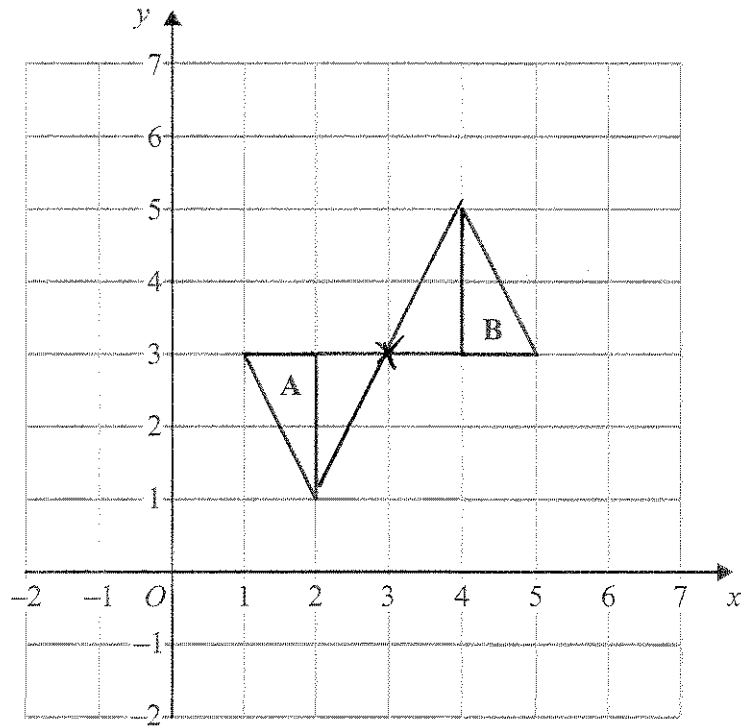

Describe fully the single transformation that maps triangle A onto triangle B.

Rotation, centre (3,3), 180°

(Total for Question 9 is 3 marks)



*10 Railtickets and Cheaptrains are two websites selling train tickets.

Each of the websites adds a credit card charge and a booking fee to the ticket price.

Railtickets

Credit card charge: 2.25% of ticket price

Booking fee: 80 pence

Cheaptrains

Credit card charge: 1.5% of ticket price

Booking fee: £1.90

Nadia wants to buy a train ticket.
The ticket price is £60 on each website.
Nadia will pay by credit card.

Will it be cheaper for Nadia to buy the train ticket from Railtickets or from Cheaptrains?

Railtickets

$$\begin{aligned} \text{Cost of ticket} &= \\ &£60 \\ &+ \\ &2.25\% \text{ of } 60 \\ &+ \\ &£0.80 \text{ (booking fee)} \end{aligned}$$

~~10/10/10~~

$$\frac{2.25}{100} \times 60 = 1.35$$

$$\begin{aligned} \text{Total} &= 60 + 1.35 + 0.80 \\ &= £62.15 \end{aligned}$$

Cheaptrains

$$\begin{aligned} \text{Cost of ticket} & \\ &£60 \\ &+ \\ &1.5\% \text{ of } 60 \\ &+ \\ &\text{Booking fee (£1.90)} \end{aligned}$$

$$\frac{1.5}{100} \times 60 = 0.90$$

$$\begin{aligned} \text{Total} &= 60 + 0.90 + 1.90 \\ &= \underline{£62.18} \end{aligned}$$

Railtickets is cheaper.

(Total for Question 10 is 4 marks)



11

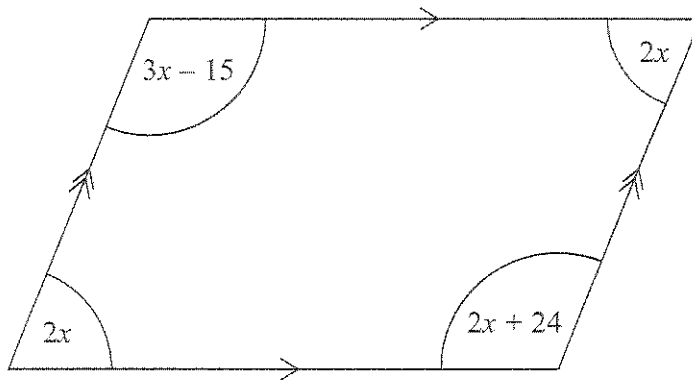

Diagram **NOT**
accurately drawn

The diagram shows a parallelogram.
The sizes of the angles, in degrees, are

- $2x$
- $3x - 15$
- $2x$
- $2x + 24$

Work out the value of x .

$$3x - 15 + 2x + 2x + 2x + 24 = 360$$

$$9x + 9 = 360$$

$$9x = 360 - 9$$

$$9x = 351$$

$$x = \frac{351}{9}$$

$$x = 39^{\circ}$$

$$x = \dots 39$$

(Total for Question 11 is 3 marks)



- 12 Jane has a carton of orange juice.
The carton is in the shape of a cuboid.

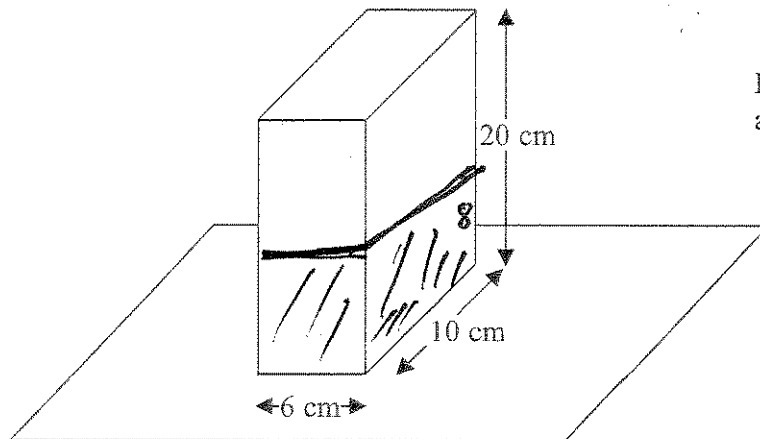

Diagram NOT
accurately drawn

The depth of the orange juice in the carton is 8 cm.

Jane closes the carton.

Then she turns the carton over so that it stands on the shaded face.

Work out the depth, in cm, of the orange juice now.

$$\text{Volume of orange juice} = 6 \times 10 \times 8 = 480 \text{ cm}^3$$

When carton turned over :

$$480 = h \times 20 \times 6$$

$$h = 480 \div (20 \times 6)$$

$$h = 4$$

4 cm

(Total for Question 12 is 3 marks)



P 4 0 6 4 5 A 0 1 3 2 8

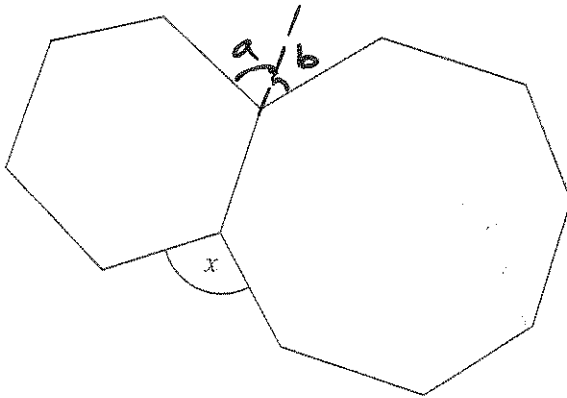

Diagram NOT
accurately drawn

The diagram shows a regular hexagon and a regular octagon.

Calculate the size of the angle marked x .
You must show all your working.

• Exterior angle of hexagon
 $360 \div 6 = 60^\circ$

• Exterior angle of octagon
 $360 \div 8 = 45^\circ$

$x = a + b = 60 + 45$

105

(Total for Question 13 is 4 marks)



14 The diagram shows the position of a lighthouse L and a harbour H .

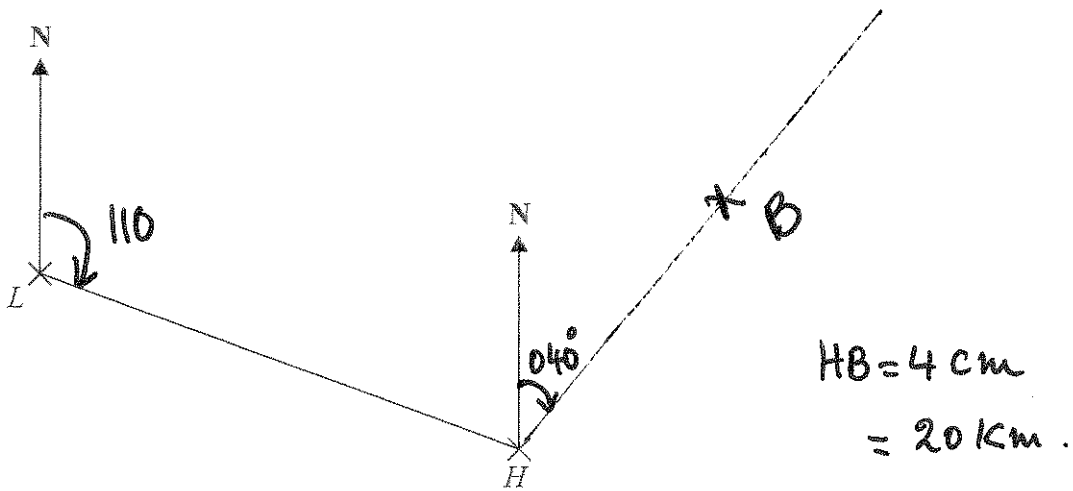

The scale of the diagram is 1 cm represents 5 km.

(a) Work out the real distance between L and H .

$LH = 7 \text{ cm}$ means real distance = 7×5

35 km
(1)

(b) Measure the bearing of H from L .

110
(1)

A boat B is 20 km from H on a bearing of 040° .

(c) On the diagram, mark the position of boat B with a cross (\times).
Label it B .

(2)

(Total for Question 14 is 4 marks)



15 Harry grows tomatoes.

This year he put his tomato plants into two groups, group A and group B.

Harry gave fertiliser to the tomato plants in group A.

He did not give fertiliser to the tomato plants in group B.

Harry weighed 60 tomatoes from group A.

The cumulative frequency graph shows some information about these weights.

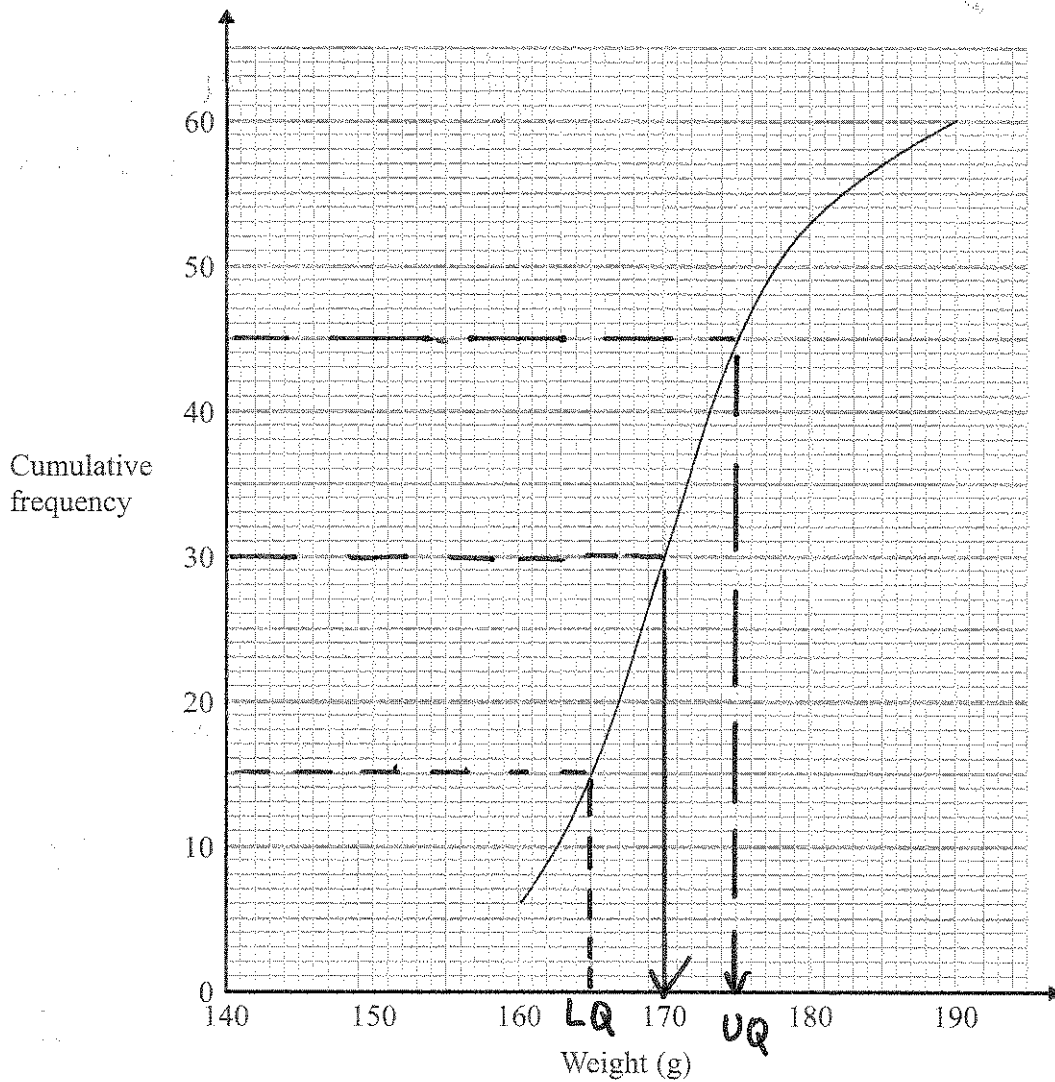

(a) Use the graph to find an estimate for the median weight.

Given by the 30th value

170

g

(1)



The 60 tomatoes from group A
 had a minimum weight of 153 grams
 and a maximum weight of 186 grams.

(b) Use this information and the cumulative frequency graph to draw a box plot for the 60 tomatoes from group A.

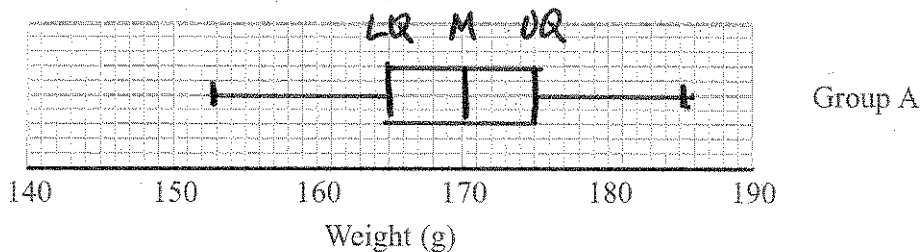

(3)

Harry did not give fertiliser to the tomato plants in group B.

Harry weighed 60 tomatoes from group B.

He drew this box plot for his results.

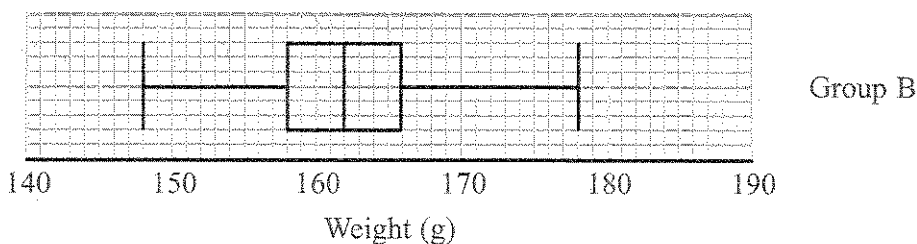

(c) Compare the distribution of the weights of the tomatoes from group A with the distribution of the weights of the tomatoes from group B.

• The IQR (group B) smaller than IQR (group A)

• The Median (group A) bigger than median (group B)

(2)

(Total for Question 15 is 6 marks)



16 (a) Simplify

$(m^{-2})^5$

$$m^{-2 \times 5} = m^{-10}$$

$$m^{-10}$$

(1)

(b) Factorise $x^2 + 3x - 10 = (x + 5)(x - 2)$

$$? + ? = +3$$

$$? \times ? = -10$$

$$(x + 5)(x - 2)$$

(2)

(Total for Question 16 is 3 marks)

17 (a) Write down the value of 10^0

$$1$$

(1)

(b) Write 6.7×10^{-5} as an ordinary number.

$$0.000067$$

$$0.000067$$

$$0.000067$$

(1)

(c) Work out the value of $(3 \times 10^7) \times (9 \times 10^6)$
Give your answer in standard form.

$$27 \times 10^7 \times 10^6$$

$$27 \times 10^{13}$$

$$2.7 \times 10^{14}$$

$$2.7 \times 10^{14}$$

(2)

(Total for Question 17 is 4 marks)



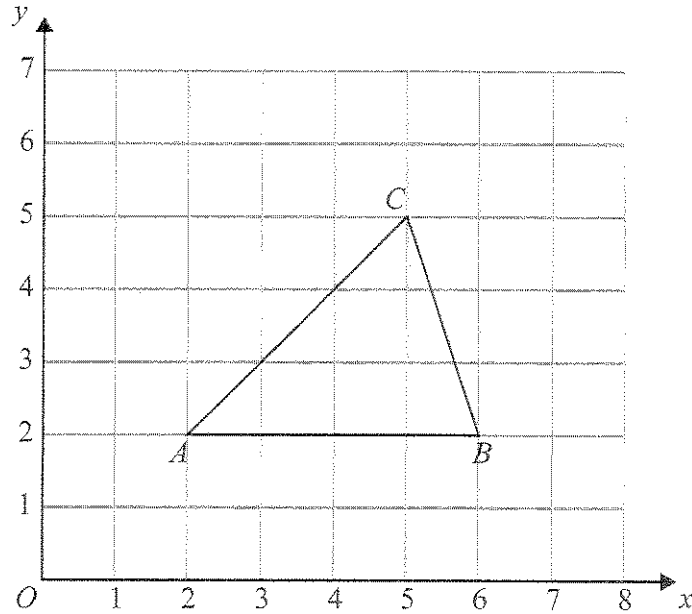

Triangle ABC is drawn on a centimetre grid.

A is the point $(2, 2)$.

B is the point $(6, 2)$.

C is the point $(5, 5)$.

Triangle PQR is an enlargement of triangle ABC with scale factor $\frac{1}{2}$ and centre $(0, 0)$.

Work out the area of triangle PQR .

$$\text{Area of } ABC = \frac{1}{2} \times 4 \times 3 = 6 \text{ cm}^2$$

$$\text{Area of } PQR = \left(\frac{1}{2}\right)^2 \times 6 = \frac{1}{4} \times 6$$

..... 1.5 cm²

(Total for Question 18 is 3 marks)



- 19 Wendy goes to a fun fair.
 She has one go at Hoopla.
 She has one go on the Coconut shy.

The probability that she wins at Hoopla is 0.4
 The probability that she wins on the Coconut shy is 0.3

- (a) Complete the probability tree diagram.

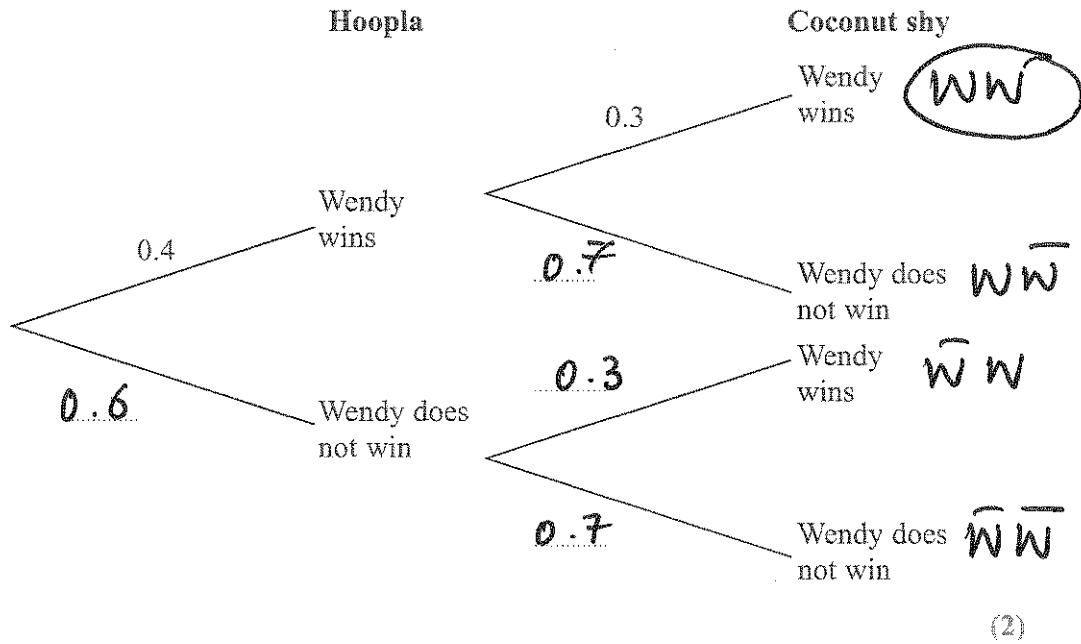

- (b) Work out the probability that Wendy wins at Hoopla and also wins on the Coconut shy.

$$P(WW) = 0.4 \times 0.3 = 0.12$$

0.12
(2)

(Total for Question 19 is 4 marks)



20 Solve the simultaneous equations

$$\begin{cases} 3x \} 5x + 2y = 11 & (1) \\ 2x \} 4x - 3y = 18 & (2) \end{cases}$$

$$\begin{array}{r} 15x + 6y = 33 \\ + \quad 8x - 6y = 36 \\ \hline 23x = 69 \end{array}$$

$$x = 69 \div 23 = 3$$

$$x = 3$$

Substitute $x = 3$ into (1) -

$$5 \times 3 + 2y = 11$$

$$15 + 2y = 11$$

$$2y = 11 - 15$$

$$2y = -4$$

$$y = -2$$

$$\begin{array}{l} x = \underline{\quad 3 \quad} \\ y = \underline{\quad -2 \quad} \end{array}$$

(Total for Question 20 is 4 marks)



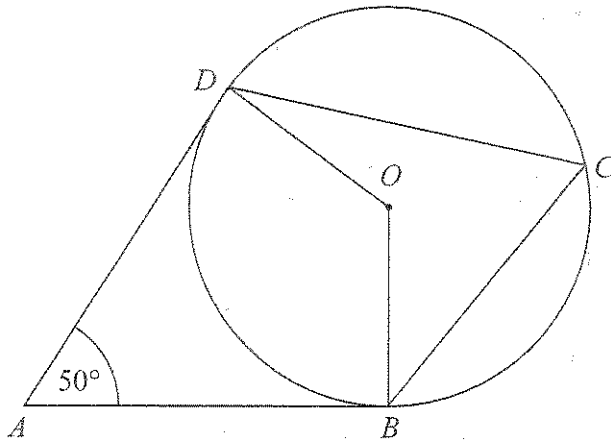

Diagram NOT
accurately drawn

B , C and D are points on the circumference of a circle, centre O .
 AB and AD are tangents to the circle.

Angle $DAB = 50^\circ$

Work out the size of angle BCD .

Give a reason for each stage in your working.

$$\angle DOB = 180^\circ - 50^\circ = 130^\circ$$

Angles in the quadrilateral $ADOB$ add up to 360
and $\angle ADO = \angle ABO = 90^\circ$ (tangents to circle).

$$\angle DOB = 2 \angle DCB$$

$$130 = 2 \times \angle DCB$$

$$\angle DCB = 65^\circ \text{ (angle at centre twice angle at circumference)}$$

$$\angle DCB = 65^\circ$$

(Total for Question 21 is 4 marks)



22 The table gives some information about the speeds, in km/h, of 100 cars.

Speed (s km/h)	Frequency
$60 < s \leq 65$	15
$65 < s \leq 70$	25
$70 < s \leq 80$	36
$80 < s \leq 100$	24

Freq. density .
 $15 \div 5 = 3$
 $25 \div 5 = 5$
 $36 \div 10 = 3.6$
 $24 \div 20 = 1.2$

(a) On the grid, draw a histogram for the information in the table.

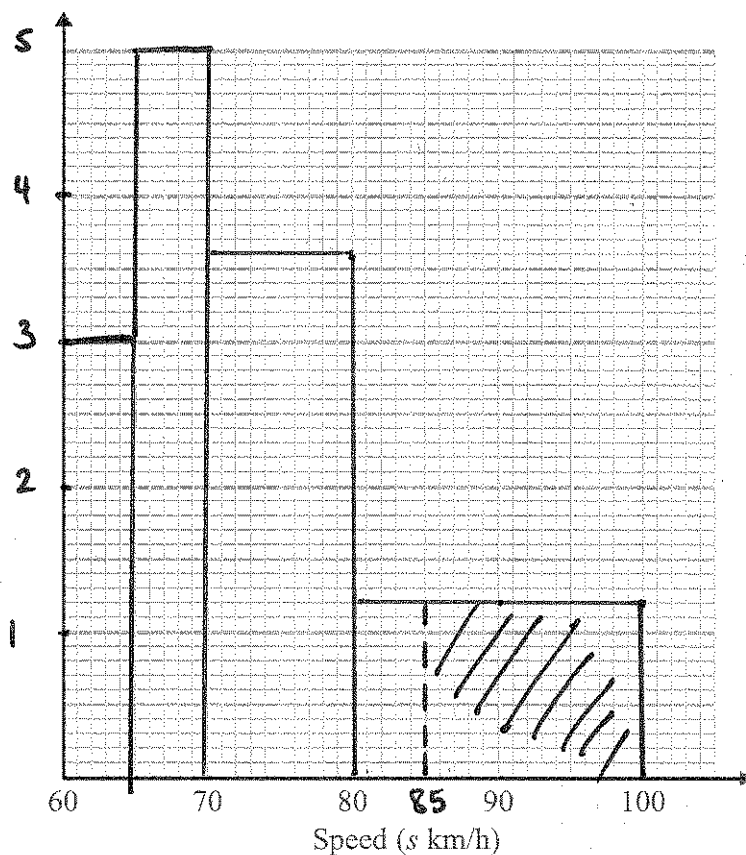

(3)

(b) Work out an estimate for the number of cars with a speed of more than 85 km/h.

Area
 18

1.2
 $15 \times 1.2 = 18$
 or $\frac{3}{4} \times 24$

18
 (2)

(Total for Question 22 is 5 marks)



23 (a) Simplify fully $\frac{x^2 + 3x - 4}{2x^2 - 5x + 3}$

$$x^2 + 3x - 4 = (x+4)(x-1)$$

$$? + ? = 3$$

$$? \times ? = -4$$

$$2x^2 - 5x + 3 = 2x^2 - 2x - 3x + 3$$

$$= 2x(x-1) - 3(x-1)$$

$$= (x-1)(2x-3)$$

$$? + ? = -5$$

$$? \times ? = 6$$

$$\frac{(x+4)(x-1)}{(x-1)(2x-3)}$$

$$\frac{x+4}{2x-3}$$

(3)

(b) Write $\frac{4}{x+2} + \frac{3}{x-2}$ as a single fraction in its simplest form.

$$\frac{4(x-2)}{(x+2)(x-2)} + \frac{3(x+2)}{(x+2)(x-2)}$$

$$\frac{4(x-2) + 3(x+2)}{(x+2)(x-2)} = \frac{4x - 8 + 3x + 6}{(x+2)(x-2)}$$

$$\frac{7x - 2}{(x+2)(x-2)}$$

(Total for Question 23 is 6 marks)

24 Express the recurring decimal $0.28\dot{1}$ as a fraction in its simplest form.

$$x = 0.28\dot{1}$$

$$10x = 2.8\dot{1}$$

$$1000x = 281.\dot{8}1$$

$$990x = 279$$

$$x = \frac{279}{990} = \frac{31}{110}$$

$$\frac{31}{110}$$

(Total for Question 24 is 3 marks)

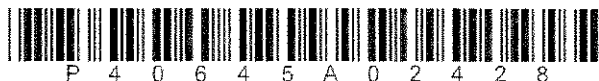

25 The diagram shows a solid metal cylinder.

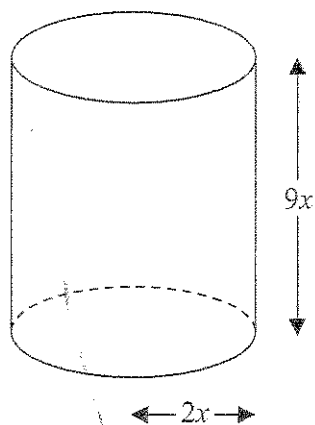

Diagram NOT
accurately drawn

The cylinder has base radius $2x$ and height $9x$.

The cylinder is melted down and made into a sphere of radius r .

Find an expression for r in terms of x .

$$\begin{aligned}\text{Volume cylinder} &= \pi \times (2x)^2 \times 9x \\ &= 36\pi x^3\end{aligned}$$

$$\text{Volume of sphere} = \frac{4}{3}\pi r^3$$

$$\frac{4}{3}\pi r^3 = 36\pi x^3$$

$$4\pi r^3 = 3 \times 36\pi x^3$$

$$r^3 = 3 \times 9x^3$$

$$r^3 = 27x^3$$

$$r = \sqrt[3]{27x^3} = 3x$$

$$r = 3x$$

(Total for Question 25 is 3 marks)



26 The graph of $y = f(x)$ is shown on each of the grids.

(a) On this grid, sketch the graph of $y = f(x - 3)$

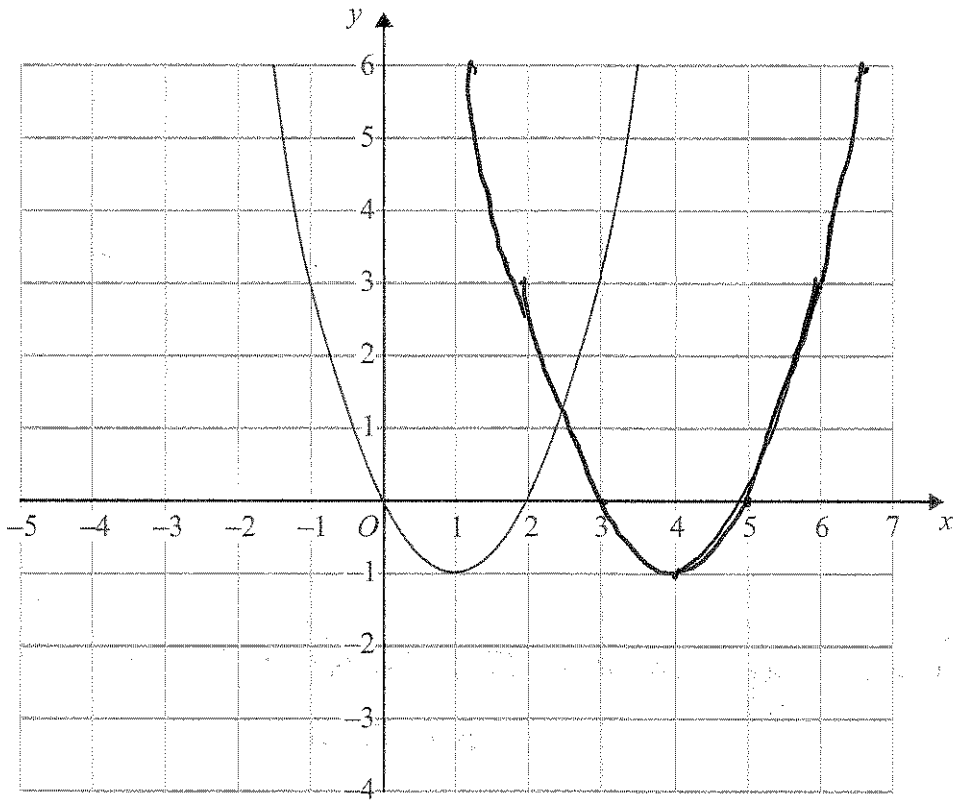

$f(x) \rightarrow f(x-3)$

(2)

Translation on X axis 3 steps right.



(b) On this grid, sketch the graph of $y = 2f(x)$

$f(x) \rightarrow 2f(x)$.
stretch on y-axis -
 $(0,0) \rightarrow (0,0)$
 $(2,0) \rightarrow (2,0)$
 $(1,-1) \rightarrow (1,-2)$

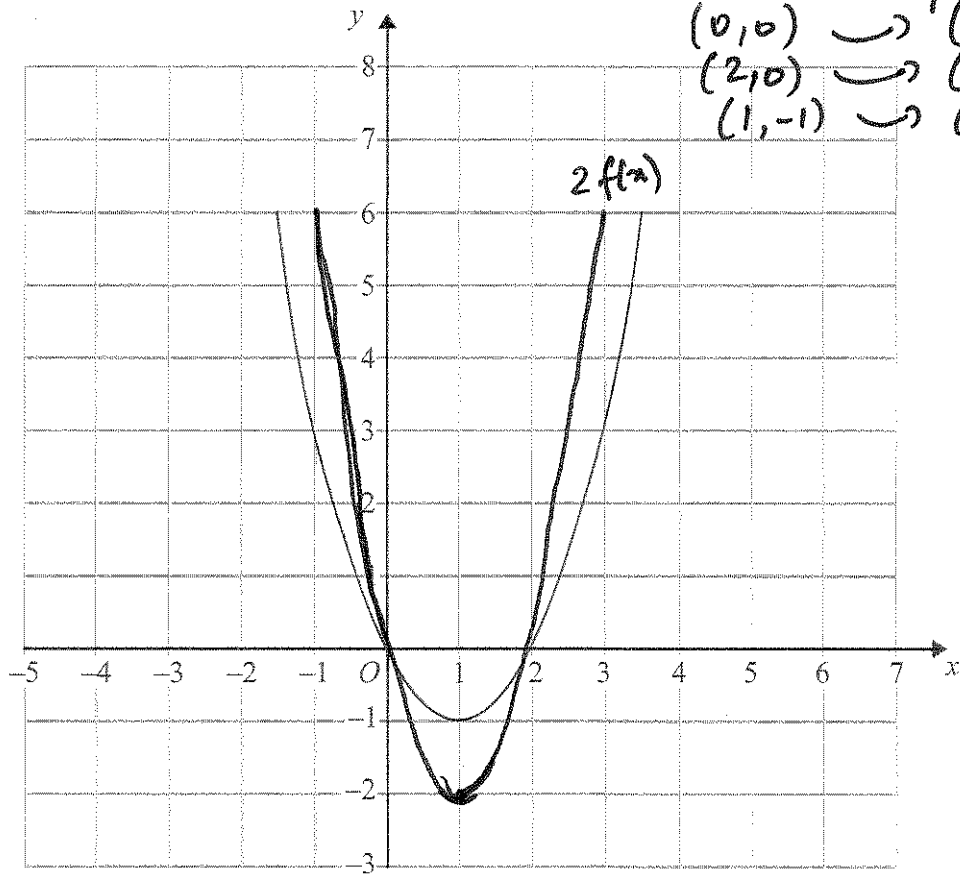

(2)

(Total for Question 26 is 4 marks)

TOTAL FOR PAPER IS 100 MARKS



BLANK PAGE

