

Centre No.						Paper Reference						Surname	Initial(s)	
Candidate No.						1	3	8	0	/	4	H	Signature	

Paper Reference(s)

**1380/4H**

**Edexcel GCSE**

**Mathematics (Linear) – 1380**

Paper 4 (Calculator)

**Higher Tier**

Monday 5 March 2012 – Afternoon

Time: 1 hour 45 minutes

Examiner's use only

--	--	--

Team Leader's use only

--	--	--



**Materials required for examination**

Ruler graduated in centimetres and millimetres, protractor, compasses, pen, HB pencil, eraser, calculator. Tracing paper may be used.

**Items included with question papers**

Nil

**Instructions to Candidates**

In the boxes above, write your centre number, candidate number, your surname, initials and signature.

Check that you have the correct question paper.

Answer ALL the questions. Write your answers in the spaces provided in this question paper.

**You must NOT write on the formulae page.**

**Anything you write on the formulae page will gain NO credit.**

If you need more space to complete your answer to any question, use additional answer sheets.

**Information for Candidates**

The marks for individual questions and the parts of questions are shown in round brackets: e.g. (2).

There are 24 questions in this question paper. The total mark for this paper is 100.

There are 24 pages in this question paper. Any blank pages are indicated.

**Calculators may be used.**

If your calculator does not have a  $\pi$  button, take the value of  $\pi$  to be 3.142 unless the question instructs otherwise.

**Advice to Candidates**

Show all stages in any calculations.

Work steadily through the paper. Do not spend too long on one question.

If you cannot answer a question, leave it and attempt the next one.

Return at the end to those you have left out.

This publication may be reproduced only in accordance with Pearson Education Ltd copyright policy.  
©2012 Pearson Education Ltd.

Printer's Leg. No.

**P40633A**

W850/R1380/57570 6/6/7/3



*Turn over*



# GCSE Mathematics (Linear) 1380

## Formulae: Higher Tier

You must not write on this formulae page.  
Anything you write on this formulae page will gain NO credit.

Volume of a prism = area of cross section  $\times$  length

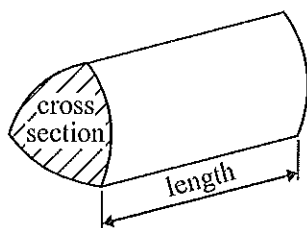

Volume of sphere =  $\frac{4}{3}\pi r^3$

Surface area of sphere =  $4\pi r^2$

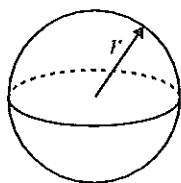

Volume of cone =  $\frac{1}{3}\pi r^2 h$

Curved surface area of cone =  $\pi r l$

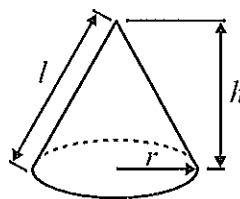

In any triangle  $ABC$

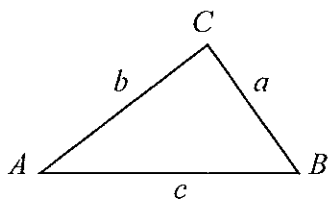

The Quadratic Equation

The solutions of  $ax^2 + bx + c = 0$

where  $a \neq 0$ , are given by

$$x = \frac{-b \pm \sqrt{b^2 - 4ac}}{2a}$$

Sine Rule  $\frac{a}{\sin A} = \frac{b}{\sin B} = \frac{c}{\sin C}$

Cosine Rule  $a^2 = b^2 + c^2 - 2bc \cos A$

Area of triangle =  $\frac{1}{2}ab \sin C$



Answer ALL TWENTY FOUR questions.

Write your answers in the spaces provided.

You must write down all stages in your working.

1. Here are the first five terms in a number sequence.

5    9    13    17    21  
 Find the 10th term in this number sequence.

$$4n+1$$

$$10^{\text{th}} \text{ term} = 4 \times 10 + 1 = 41$$

$4n$      $4 \times 1 = 4$   
 but we need 5 for the first term so we add 1.  
 $4n+1$

..... 41 .....

(Total 2 marks)

Q1

2. A rugby team played six games.  
 The mean score for the six games is 14.5  
 The rugby team played one more game.  
 The mean score for all seven games is 16

Work out the number of points the team scored in the seventh game.

$$\rightarrow 6 \times 14.5 = 87$$

$$\rightarrow 7 \times 16 = 112$$

$$\rightarrow 112 - 87 = 25$$

..... 25 ..... points

(Total 2 marks)

Q2



3. Rosie and Jim are going on holiday to the USA.

Jim changes £350 into dollars (\$).

The exchange rate is £1 = \$1.34

(a) Work out how many dollars (\$) Jim gets.

$$\begin{array}{l} \times 350 \swarrow \quad \text{£}1 = \$1.34 \quad \searrow \times 350 \\ \text{£}350 = \$469 \end{array}$$

\$ ..... 469 .....  
(2)

In the USA Rosie sees some jeans costing \$67

In London the same make of jeans costs £47.50

The exchange rate is still £1 = \$1.34



(b) Work out the difference between the cost of the jeans in the USA and in London.  
Give your answer in pounds (£).

$$\text{London} = \text{£} 47.50$$

$$\begin{array}{l} \text{USA} = \text{£}1 = \$1.34 \\ \times 50 \swarrow \quad \text{£}50 = \$67 \quad \searrow \times 50 \end{array}$$

$$\text{£}50 - \text{£}47.50 = \text{£}2.50$$

£ ..... 2.50 .....  
(3)

(Total 5 marks)

Q3



4. John needs 4 tyres for his car.

He pays for 3 tyres and gets one tyre free.  
The tyres cost £65 each plus VAT at 20%.

Work out how much in total John pays for the tyres.

**Offer of the week**  
4 for the price of 3



£65 each plus VAT

$$£65 + 20\% =$$

$$10\% \text{ of } £65 = £6.50$$

$$\therefore 20\% \text{ of } £65 = (£6.50 \times 2) = £13$$

$$\text{each tyre costs } £65 + £13 = £78$$

only pays for 3

$$£78 \times 3 = £234$$

£ 234 .....

Q4

(Total 4 marks)

5. (a) Use your calculator to work out  $\frac{\sqrt{2.5^2 + 3.75}}{3.9 - 1.7}$

Write down all the figures on your calculator display.  
You must give your answer as a decimal.

$$2.5^2 = 6.25$$

$$\frac{\sqrt{10}}{2.2} = \frac{3.16227766}{2.2} =$$

$$6.25 + 3.75 = 10$$

1.43739894

(3)

(b) Write your answer to part (a) correct to 2 decimal places.

1.44 .....

(1)

Q5

(Total 4 marks)



6. The equation  $x^3 + 3x = 41$

has a solution between 3 and 4

Use a trial and improvement method to find this solution.

Give your answer correct to one decimal place.

You must show all your working.

$x$	$x^3 + 3x$	Target=41 Too high or Too low?
3	36	low
4	76	High
3.2	42.368	High
3.1	39.091	low
3.15	40.71	low

} Trapped.

$\therefore x = 3.2$

$x = 3.2$

(Total 4 marks)

Q6



7.

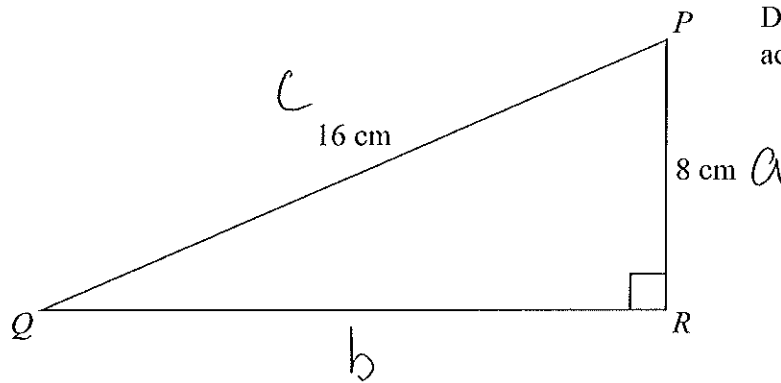

Diagram NOT accurately drawn

$PQR$  is a right-angled triangle.

$PQ = 16$  cm.

$PR = 8$  cm.

Calculate the length of  $QR$ .

Give your answer correct to 2 decimal places.

$$c^2 - a^2 = b^2$$

$$16^2 - 8^2 = b^2$$

$$256 - 64 = b^2$$

$$192 = b^2$$

$$\sqrt{192} = \sqrt{b^2}$$

$$13.86 = b$$

..... 13.86 cm

Q7

(Total 3 marks)



8. (a) Simplify  $x^5 \times x^4$

$$x^{5+4} = x^9$$

$$\frac{x^9}{(1)}$$

(b) Simplify  $y^7 \div y^2$

$$y^{7-2} = y^5$$

$$\frac{y^5}{(1)}$$

(c) Expand and simplify  $3(2a+5) + 5(a-2)$

$$6a + 15 + 5a - 10$$

collect a's  $6a + 5a = 11a$

collect numbers  $15 - 10 = 5$

$$\frac{11a + 5}{(2)}$$

(d) Expand and simplify  $(y+5)(y+7)$

	y	+7
y	y <sup>2</sup>	7y
+5	5y	35

$$y^2 + 7y + 5y + 35$$

$$\frac{y^2 + 12y + 35}{(2)}$$

(e) Factorise  $p^2 - 6p + 8$

$$\frac{(p-4)(p-2)}{(2)}$$

Q8

(Total 8 marks)





9. Riki has a packet of flower seeds.

The table shows each of the probabilities that a seed taken at random will grow into a flower that is pink or red or blue or yellow.

Colour	pink	red	blue	yellow	white
Probability	0.15	0.25	0.20	0.16	

(a) Work out the probability that a seed taken at random will grow into a white flower.

$$0.15 + 0.25 + 0.2 + 0.16 = 0.76$$

$$1 - 0.76 = 0.24$$

$$\begin{array}{r} 0.24 \\ \hline \end{array} \quad (2)$$

There are 300 seeds in the packet.

All of the seeds grow into flowers.

(b) Work out an estimate for the number of red flowers.

$$300 \times 0.25 = 75$$

$$\begin{array}{r} 75 \\ \hline \end{array} \quad (2)$$

(Total 4 marks)

Q9

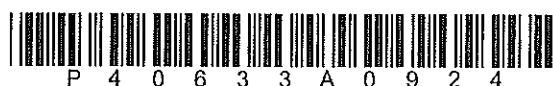

10. Caleb measured the heights of 30 plants.

The table gives some information about the heights,  $h$  cm, of the plants.

Height ( $h$ cm) of plants	Frequency $F$	mid point	$F \times x$
$0 < h \leq 10$	2	5	10
$10 < h \leq 20$	8	15	120
$20 < h \leq 30$	9	25	225
$30 < h \leq 40$	7	35	245
$40 < h \leq 50$	4	45	180

Work out an estimate for the mean height of a plant.

$$\sum fx = 780$$

$$\sum f = 30$$

$$780 \div 30 = 26$$

..... 26 ..... cm

(Total 4 marks)

Q10



11. (a) On the number line below, show the inequality  $-2 < y < 3$

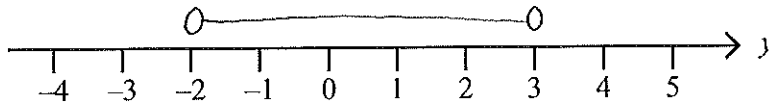

(1)

(b) Here is an inequality, in  $x$ , shown on a number line.

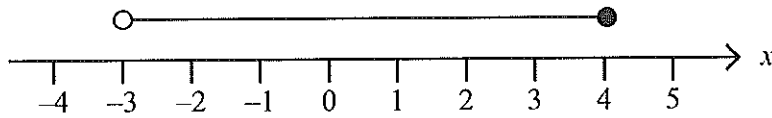

Write down the inequality.

$-3 < x \leq 4$

(2)

(c) Solve the inequality  $4t - 5 > 9$

$$4t - 5 > 9$$

$$\begin{matrix} (+5) & (+5) \\ 4t & > 14 \end{matrix}$$

$$4t > 14$$

$$t > \frac{14}{4}$$

$$t > 3.5$$

$t > 3.5$

(2)

Q11

(Total 5 marks)

12. Sylvic shares £45 between Ann, Bob and Cath in the ratio 2 : 3 : 4

Work out the amount each person gets.

$$2 + 3 + 4 = 9$$

$$£45 \div 9 = £5$$

$$\text{Ann} = 2 \times £5 = £10$$

$$\text{Bob} = 3 \times £5 = £15$$

$$\text{Cath} = 4 \times £5 = £20$$

Ann £10

Bob £15

Cath £20

Q12

(Total 3 marks)



13.  $ABCD$  is a trapezium.

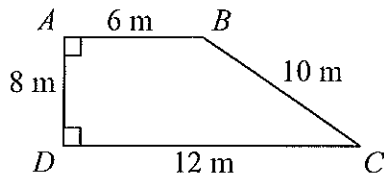

Diagram NOT accurately drawn

Work out the area of the trapezium.

Find average base.  $\frac{6+12}{2} = \frac{18}{2} = 9$

Average Base  $\times$  height

$9 \times 8 = 72$

..... 72 m<sup>2</sup>

Q13

(Total 2 marks)

14.  $PQR$  is a right-angled triangle.

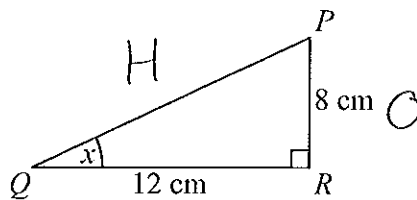

Diagram NOT accurately drawn

$PR = 8$  cm.  
 $QR = 12$  cm.

- (a) Find the size of the angle marked  $x$ .  
Give your answer correct to 1 decimal place.

$\tan x = \frac{8}{12}$

$x = \tan^{-1}\left(\frac{8}{12}\right)$

$x = 33.7$

..... 33.7 .  
(3)



XYZ is a different right-angled triangle.

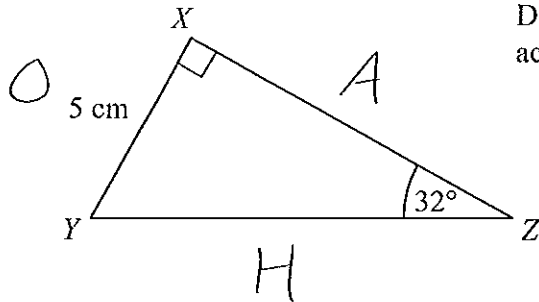

Diagram NOT accurately drawn

XY = 5 cm.  
Angle Z = 32°.

- (b) Calculate the length YZ.  
Give your answer correct to 3 significant figures.

$$\sin 32 = \frac{5}{H}$$

$$H = \frac{5}{\sin 32}$$

$$H = 9.435$$

9.44 cm  
..... cm  
(3)

(Total 6 marks)

Q14



15.

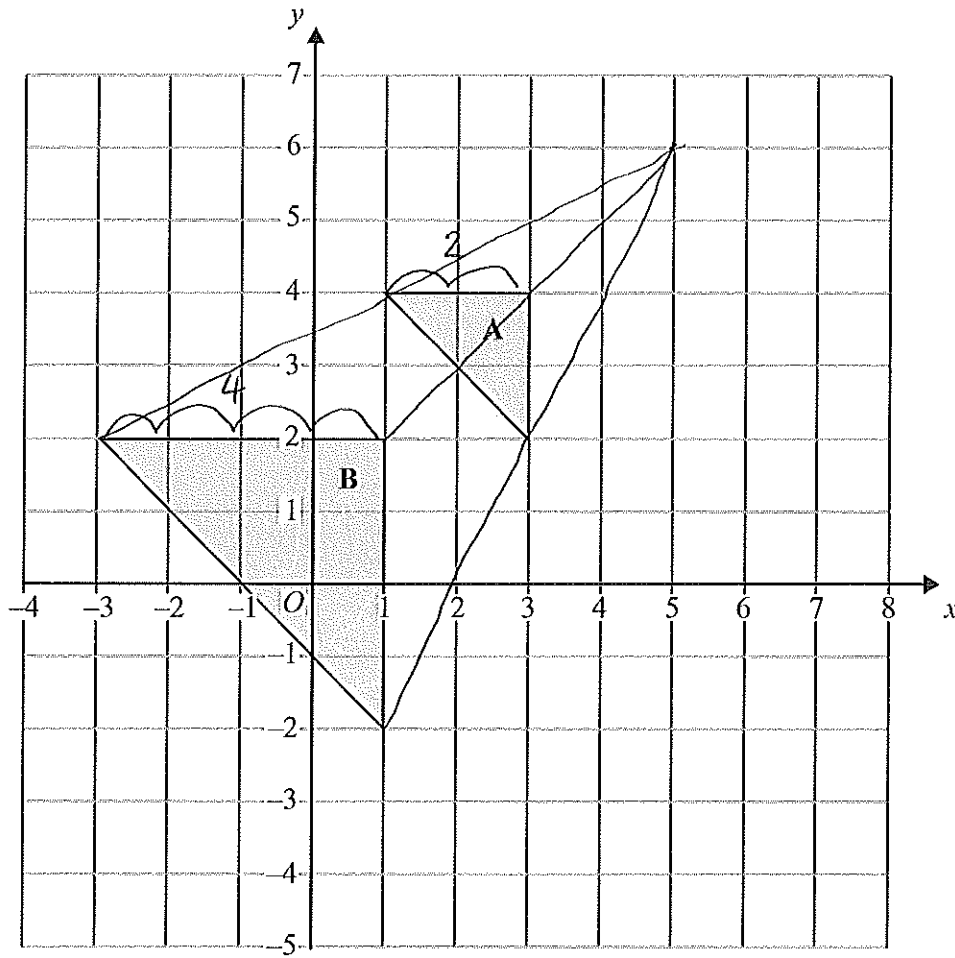

Triangle A and triangle B are drawn on the grid.

(a) Describe fully the single transformation which maps triangle A onto triangle B.

Enlargement, scale factor 2,  
 centre of enlargement = (5, 6)

(3)



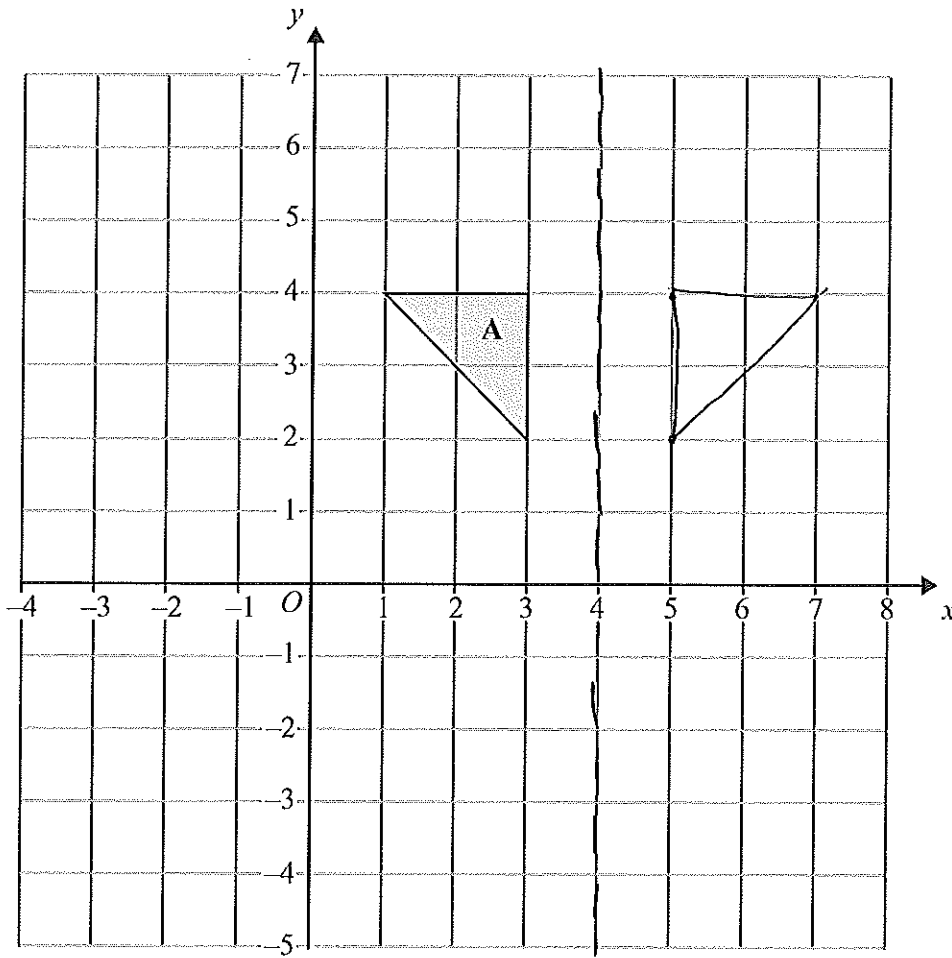

(b) Reflect triangle A in the line  $x = 4$

(2) Q15

(Total 5 marks)



16. This frequency table gives information about the ages of 60 teachers.

Age ( $A$ ) in years	Frequency
$20 < A \leq 30$	12
$30 < A \leq 40$	15
$40 < A \leq 50$	18
$50 < A \leq 60$	12
$60 < A \leq 70$	3

(a) Complete the cumulative frequency table.

Age ( $A$ ) in years	Cumulative frequency
$20 < A \leq 30$	12
$20 < A \leq 40$	27
$20 < A \leq 50$	45
$20 < A \leq 60$	57
$20 < A \leq 70$	60

(1)

(b) On the grid opposite, draw a cumulative frequency graph for this information.

(2)

(c) Use your cumulative frequency graph to find an estimate for the median age.

..... 42 years  
(2)

(d) Use your cumulative frequency graph to find an estimate for the number of teachers older than 55 years.

$$60 - 52 = 8$$

..... 8  
(2)





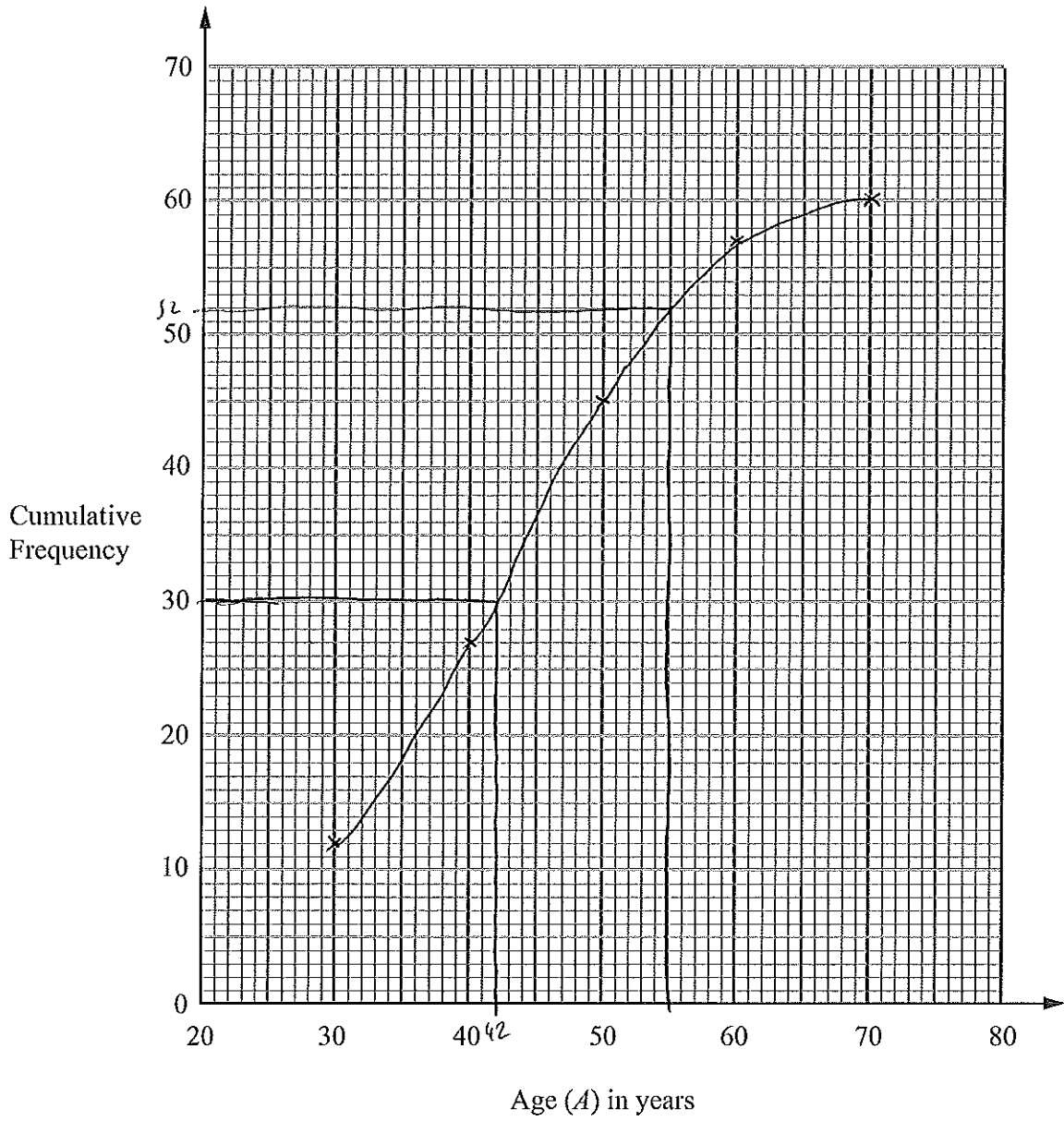

Q16

(Total 7 marks)



17.

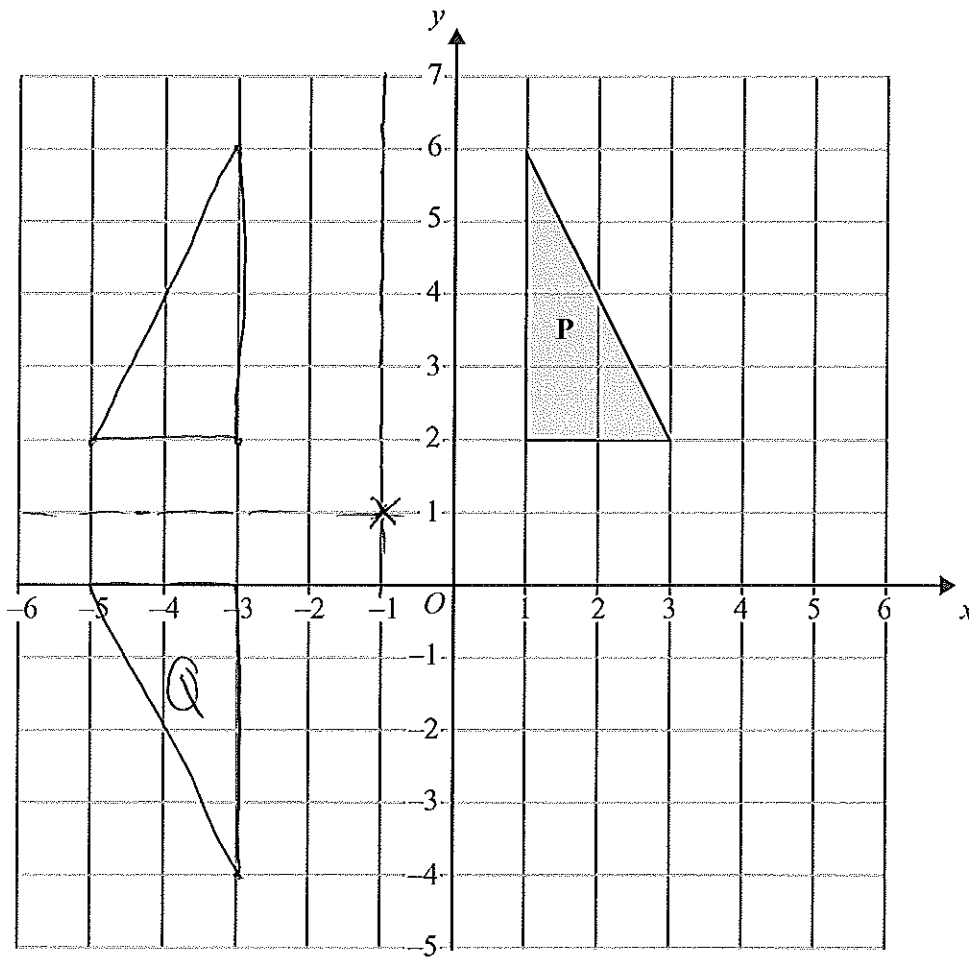

Triangle **P** is drawn on a coordinate grid.

The triangle **P** is reflected in the line  $x = -1$  and then reflected in the line  $y = 1$  to give triangle **Q**.

Describe fully the single transformation which maps triangle **P** onto triangle **Q**.

Rotation of  $180^\circ$  around the  
 centre  $(-1, 1)$

(Total 3 marks)

Q17



18. Solve the equations

$$\begin{aligned} \textcircled{1} \quad & 3x + 5y = 19 \quad \times 4 \text{ to give } \textcircled{3} \\ \textcircled{2} \quad & 4x - 2y = -18 \quad \times 3 \text{ to give } \textcircled{4} \end{aligned}$$

$$\textcircled{3} \quad 12x + 20y = 76$$

$$\textcircled{4} \quad 12x - 6y = -54$$

$$\textcircled{3} - \textcircled{4} = 26y = 130$$

$$y = \frac{130}{26} = 5$$

Sub  $y=5$  into  $\textcircled{1}$

$$3x + 5y = 19$$

$$3x + 25 = 19$$

$$(-25) \quad (-25)$$

$$3x = -6$$

$$x = \frac{-6}{3} = -2$$

$$\begin{aligned} x &= \frac{-2}{\dots\dots\dots} \\ y &= \frac{5}{\dots\dots\dots} \end{aligned}$$

Q18

(Total 4 marks)

19. Solve the equation  $5x^2 + 8x - 6 = 0$   
Give each solution correct to 2 decimal places.

$$x = \frac{-b \pm \sqrt{b^2 - 4ac}}{2a}$$

$$x = \frac{-8 \pm \sqrt{8^2 - 4 \times 5 \times -6}}{2 \times 5}$$

$$x = \frac{-8 \pm \sqrt{64 + 120}}{10}$$

$$x = \frac{-8 \pm \sqrt{184}}{10}$$

$$\begin{aligned} x &= \frac{-8 + \sqrt{184}}{10} \\ &= 0.5564 \end{aligned}$$

$$\begin{aligned} x &= \frac{-8 - \sqrt{184}}{10} \\ &= -2.1565 \end{aligned}$$

$$0.56 \text{ or } -2.16$$

Q19

(Total 3 marks)



20. Here is a triangle  $ABC$ .

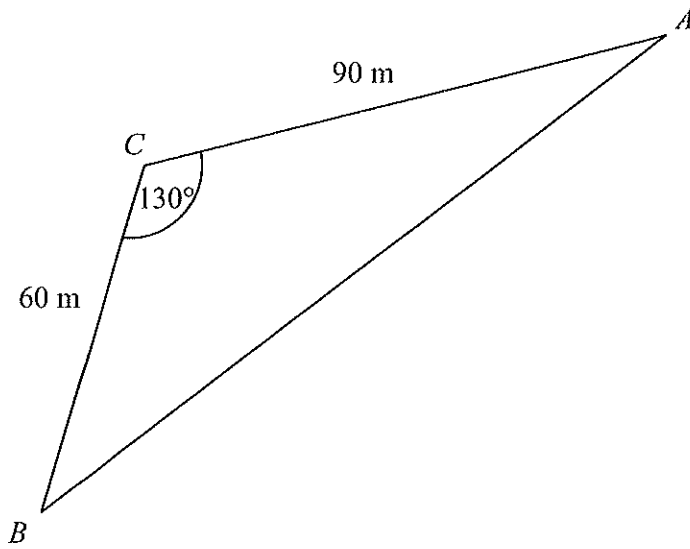

Diagram **NOT** accurately drawn

$AC = 90$  m.  
 $BC = 60$  m.  
 Angle  $ACB = 130^\circ$ .

Calculate the perimeter of the triangle.  
 Give your answer correct to one decimal place.

$$c^2 = 60^2 + 90^2 - (2 \times 60 \times 90 \times \cos 130^\circ)$$

$$c^2 = 3600 + 8100 - 10800 \times -0.6427876$$

$$c^2 = 11700 + 6942.106$$

$$c^2 = 18642.106$$

$$c = \sqrt{18642.106}$$

$$c = 136.536$$

$$\text{Perimeter} = 60 + 90 + 136.536$$

$$= 286.536$$

..... 286.5 m

(Total 4 marks)

Q20

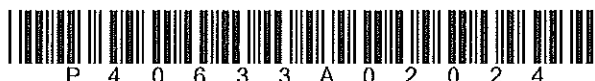

21. The table shows information about the lengths of time,  $t$  minutes, it took some students to do their maths homework last week.

Time ( $t$ minutes)	Frequency	Class width	Frequency $\div$ class width
$0 < t \leq 10$	4	10	0.4
$10 < t \leq 15$	8	5	1.6
$15 < t \leq 20$	24	5	4.8
$20 < t \leq 30$	16	10	1.6
$30 < t \leq 50$	5	20	0.25

Draw a histogram for this information.

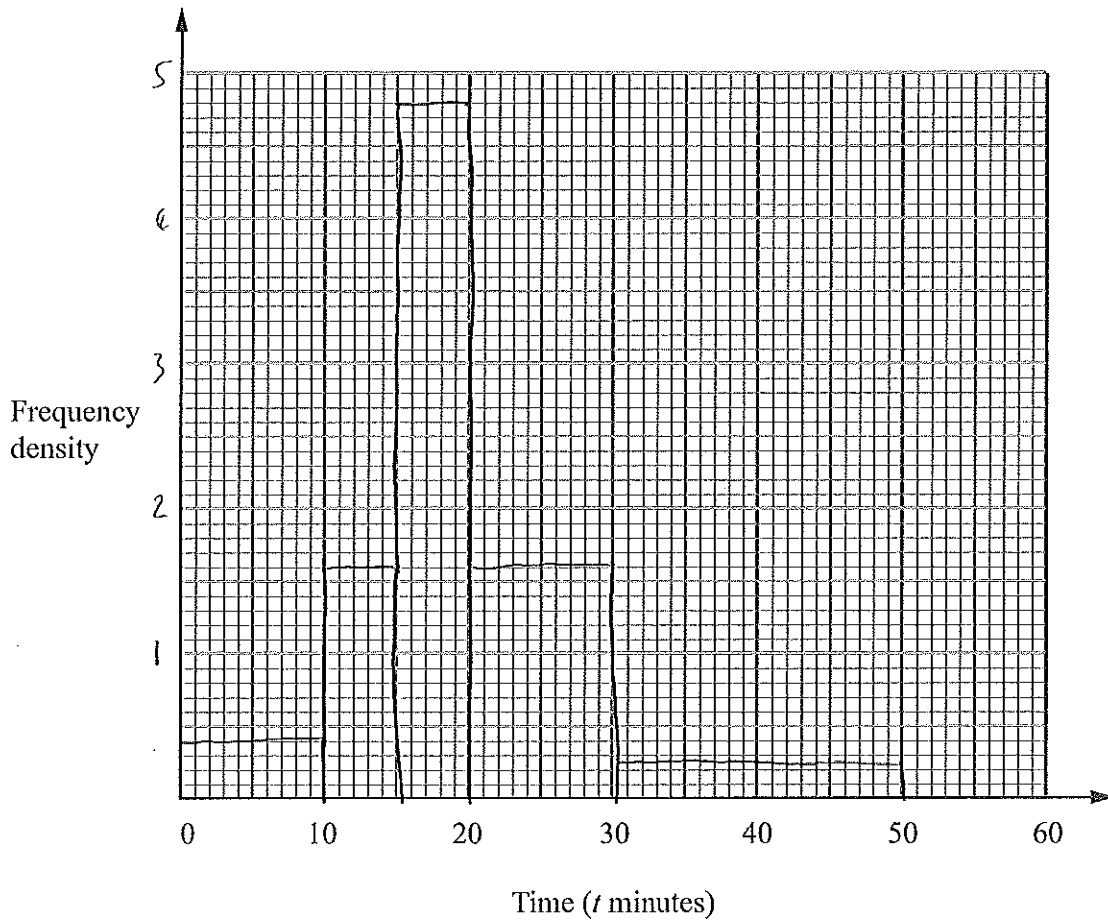

Q21

(Total 3 marks)



22. The average fuel consumption ( $c$ ) of a car, in kilometres per litre, is given by the formula

$$c = \frac{d}{f}$$

where  $d$  is the distance travelled, in kilometres, and  $f$  is the fuel used, in litres.

$d = 163$  correct to 3 significant figures.

$f = 45.3$  correct to 3 significant figures.

By considering bounds, work out the value of  $c$  to a suitable degree of accuracy.

You must show **all** of your working **and** give a reason for your final answer.

$$163 \quad \begin{array}{l} \text{upper} = 163.5 \\ \text{lower} = 162.5 \end{array}$$

$$45.3 \quad \begin{array}{l} \text{upper} = 45.35 \\ \text{lower} = 45.25 \end{array}$$

$$\text{Upper bound} = \frac{163.5}{45.25} = 3.61326$$

$$\text{Lower bound} = \frac{162.5}{45.35} = 3.58324$$

$\therefore 3.6$  because upper and lower bound both round to 3.6

$$c = 3.6$$

(Total 5 marks)

Q22



23.

Diagram NOT accurately drawn

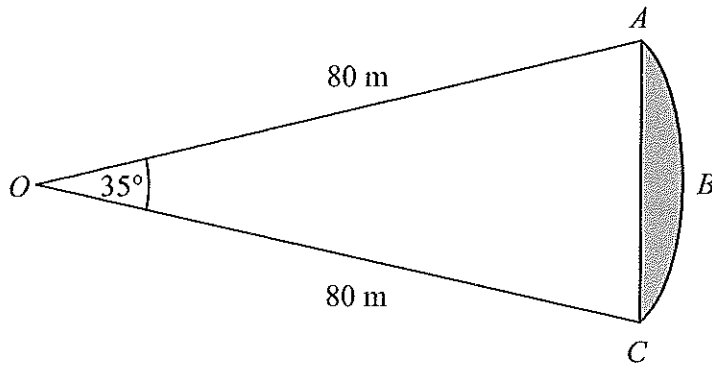

$ABC$  is an arc of a circle centre  $O$  with radius  $80$  m.  
 $AC$  is a chord of the circle.  
 Angle  $AOC = 35^\circ$ .

Calculate the area of the shaded region.  
 Give your answer correct to 3 significant figures.

Area of sector =

$$\frac{35}{360} \times \pi \times 80 \times 80$$

$$= 1954$$

Area of triangle =

$$\frac{1}{2} \times 80 \times 80 \times \sin 35^\circ$$

$$= 1835$$

Area of segment =

$$1954 - 1835 = 119$$

.....119..... m<sup>2</sup>

(Total 5 marks)

Q23



24. Solve  $\frac{5(2x+1)^2}{4x+5} = 5x-1$

$$5(2x+1)^2 = (5x-1)(4x+5)$$

$$5(4x^2+4x+1) = \cancel{20x^2} + 21x - 5$$

$$20x^2 + 20x + 5 = 20x^2 + 21x - 5$$

$$\begin{array}{r} (-20x^2) \quad \quad (-20x^2) \\ \hline 20x + 5 = 21x - 5 \\ (-20x) \quad (-20x) \\ \hline 5 = x - 5 \\ (+5) \quad (+5) \\ \hline 10 = x \end{array}$$

2x	+1
2x	4x <sup>2</sup>
+1	2x

$$4x^2 + 4x + 1$$

5x	-1
4x	20x <sup>2</sup>
+5	-4x

$$20x^2 + 21x - 5$$

10

(Total 5 marks)

Q24

TOTAL FOR PAPER: 100 MARKS

END

