

Centre No.						Paper Reference						Surname	Initial(s)	
Candidate No.						1	3	8	0	/	1	F	Signature	

Paper Reference(s)

1380/1F

Edexcel GCSE

Mathematics (Linear) – 1380

Paper 1 (Non-Calculator)

Foundation Tier



Wednesday 9 November 2011 – Afternoon

Time: 1 hour 30 minutes

Examiner's use only

--	--	--

Team Leader's use only

--	--	--



Materials required for examination

Ruler graduated in centimetres and millimetres, protractor, compasses, pen, HB pencil, eraser.
Tracing paper may be used.

Items included with question papers

Nil

Instructions to Candidates

In the boxes above, write your centre number, candidate number, your surname, initials and signature. Check that you have the correct question paper. Answer ALL the questions. Write your answers in the spaces provided in this question paper. **You must NOT write on the formulae page.** Anything you write on the formulae page will gain **NO** credit. If you need more space to complete your answer to any question, use additional answer sheets.

Information for Candidates

The marks for individual questions and the parts of questions are shown in round brackets: e.g. (2). There are 25 questions in this question paper. The total mark for this paper is 100. There are 28 pages in this question paper. Any blank pages are indicated. **Calculators must not be used.**

Advice to Candidates

Show all stages in any calculations. Work steadily through the paper. Do not spend too long on one question. If you cannot answer a question, leave it and attempt the next one. Return at the end to those you have left out.

This publication may be reproduced only in accordance with Edexcel Limited copyright policy. ©2011 Edexcel Limited.

Printer's Log. No.

P40078A

W850/R1380/57570 6/6/6/4/3



Turn over

edexcel
advancing learning, changing lives

GCSE Mathematics (Linear) 1380

Formulae: Foundation Tier

**You must not write on this formulae page.
Anything you write on this formulae page will gain NO credit.**

Area of trapezium = $\frac{1}{2}(a+b)h$

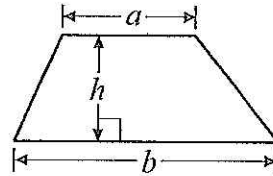

Volume of prism = area of cross section \times length

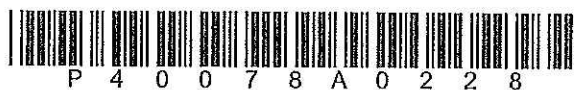
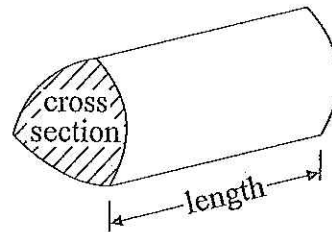

Answer ALL TWENTY FIVE questions.

Write your answers in the spaces provided.

You must write down all stages in your working.

You must NOT use a calculator.

1. (a) Write down the number one thousand two hundred and eighty four in figures.

1284 (1)

- (b) Write the number 4067 in words.

FOUR THOUSAND AND SIXTY SEVEN (1)

- (c) What is the value of the figure 2 in the number 3027?

TWENTY (1)

- (d) Write 1476 correct to the nearest hundred.

1500 (1)

(Total 4 marks)

Q1



2. At the beginning of term a school had 960 students.
By the end of term 23 students had left
and 16 students had joined the school.

(a) How many students did the school have at the end of the term?

$$\begin{array}{r} 960 \\ - 23 \\ \hline 937 \end{array}$$

$$\begin{array}{r} 937 \\ + 16 \\ \hline 953 \end{array}$$

.....953.....
(2)

The school day starts at 8 30 am and finishes at 3 30 pm.

Students have 20 minutes for morning break and 40 minutes for lunch break.
Students have lessons for the rest of the school day.

(b) Work out how many hours of lessons students have each day.

$$\begin{array}{r} 20 \\ + 40 \\ \hline 60 \end{array}$$

There is 7 hours in a school day

60 minutes = 1 hour

$$7 - 1 = 6$$

.....6..... hours
(3)

(Total 5 marks)

Q2



3. Amir asked some people which was their favourite town for shopping. He drew a bar chart to show information about their answers.

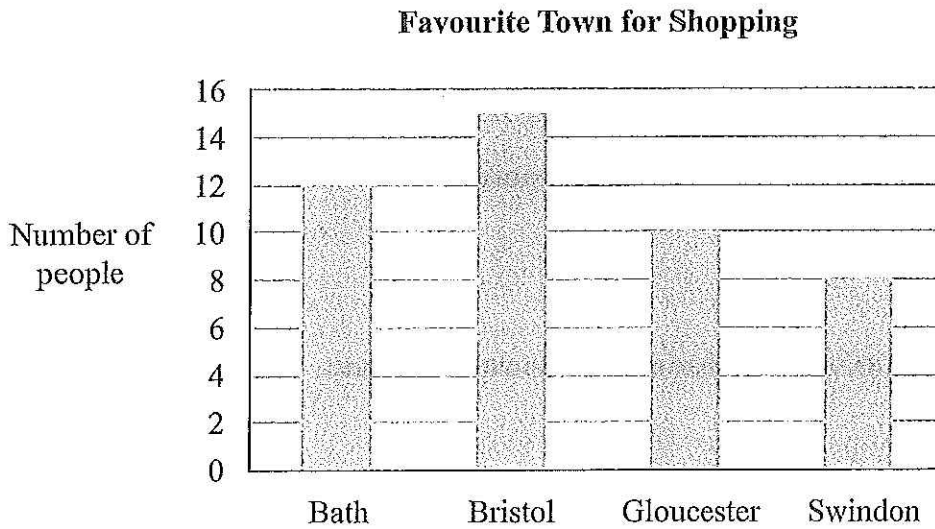

- (a) How many people said that Bath was their favourite town for shopping?

12
.....
(1)

More people said that Bristol was their favourite town for shopping than said Swindon was.

- (b) How many more?

$$15 - 8 = 7$$

7
.....
(1)

- (c) Which town was the mode?

BRISTOL
.....
(1)

(Total 3 marks)

Q3



4. Poppy thinks of a rule for a number pattern.

Her rule is

$$\boxed{\times 2}$$

Here are the first 3 numbers in her number pattern.

3 6 12

(a) Write down the next number in Poppy's number pattern.

$$12 \times 2 = 24$$

..... 24 (1)

Jasper thinks of a rule for a number pattern.

He uses his rule to write down 2 5 8 11

(b) Complete the box to show Jasper's rule.

$$\boxed{+ 3}$$

(1)

Carl thinks of a rule for a number pattern.

His rule is

$$\boxed{\times 2 + 1}$$

He starts with the number 3

(c) Write down the second number and the third number in his number pattern.

..... 7 and 15 (1)

(Total 3 marks)

Q4



5. The table gives information about temperatures at 1 am in some cities on 2 days.

City	Temperature	
	Monday	Tuesday
Newcastle	-11°C	-3°C
Leeds	-12°C	-3°C
Cardiff	-6°C	2°C
London	-7°C	1°C
Truro	-2°C	5°C

(a) Write down the name of the city which had the lowest temperature on Monday.

LEEDS
.....
(1)

(b) Work out the difference in the temperatures between Newcastle and London on Monday.

4 °C
.....
(1)

(c) Work out the increase in temperature in Truro between 1 am Monday and 1 am Tuesday.

7 °C
.....
(1)

Gareth lives in Cardiff.

At 1 am Monday, he predicts that the temperature in Cardiff is going to rise by 2°C every hour.

Using Gareth's prediction,

(d) work out the time at which the temperature will rise to -2°C.

1am -6
2am -4
3am -2

3am
.....
(1)

(Total 4 marks)

Q5



6.

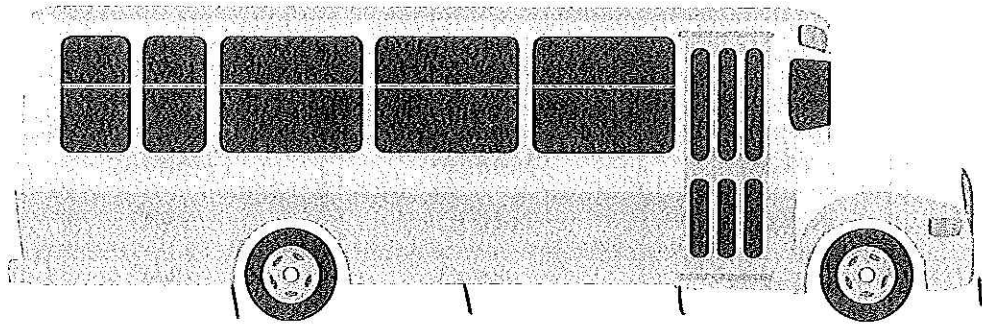

The diagram shows a man and a bus.
 The man and the bus are drawn to the same scale.
 The man is of average height.

(i) Write down an estimate for the height of the man.

1.6 meters

(ii) Find an estimate for the length of the bus.

$$1.6 \times 4$$

$$1 \times 4 = 4$$

$$0.6 \times 4 = 2.4$$

$$\underline{\hspace{1cm}}$$

6.4 meters

6.4 meters

(Total 3 marks)

Q6

7. (a) Work out $\frac{1}{4}$ of £24

$$24 \div 4 = 6$$

£ 6
 (1)

(b) Work out 10% of 400 kg.

$$400 \div 10 = 40$$

40 kg
 (1)

(Total 2 marks)

Q7



8. Bill has two parcels on a trolley.
 The first parcel weighs 3.45 kg.
 The second parcel weighs 1.8 kg.

Bill cannot put more than a total weight of 10 kg on the trolley.

Bill puts a third parcel on the trolley.

- (a) Work out the largest possible weight of the third parcel.

$$\begin{array}{r} 3.45 \\ + 1.80 \\ \hline 5.25 \end{array}$$

$$\begin{array}{r} 10.00 \\ - 5.25 \\ \hline 4.75 \end{array}$$

..... 4.75 kg
 (3)

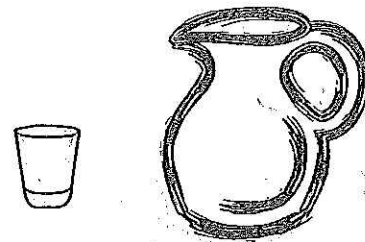

Nimer has a jug.
 There are 2 litres of water in the jug.
 Nimer wants to fill some glasses with water from the jug.
 He will fill each glass with exactly 300 ml of water.

- (b) Work out the largest number of glasses that Nimer can fill.

$$2 \text{ litres} = 2000$$

$$2000 \div 300 = 6.666$$

..... 6
 (2)

(Total 5 marks)

Q8



9.

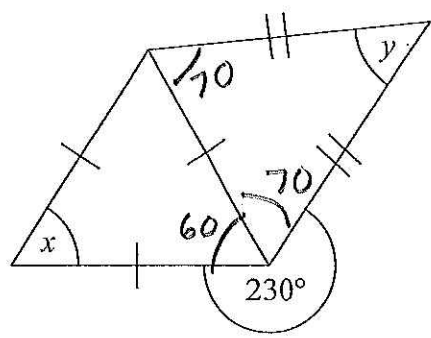

Diagram NOT accurately drawn

The diagram shows an equilateral triangle and an isosceles triangle.

(a) Work out the size of the angle marked x .

60° (1)

(b) Work out the size of the angle marked y .

$$\begin{array}{r}
 230 \\
 + 60 \\
 \hline
 290
 \end{array}$$

$$\begin{array}{r}
 360 \\
 - 290 \\
 \hline
 070
 \end{array}$$

$$\begin{array}{r}
 70 \\
 + 70 \\
 \hline
 140
 \end{array}$$

$$\begin{array}{r}
 180 \\
 - 140 \\
 \hline
 40
 \end{array}$$

40° (3)

(Total 4 marks)

Q9



10. Here are some triangles drawn on a square grid.

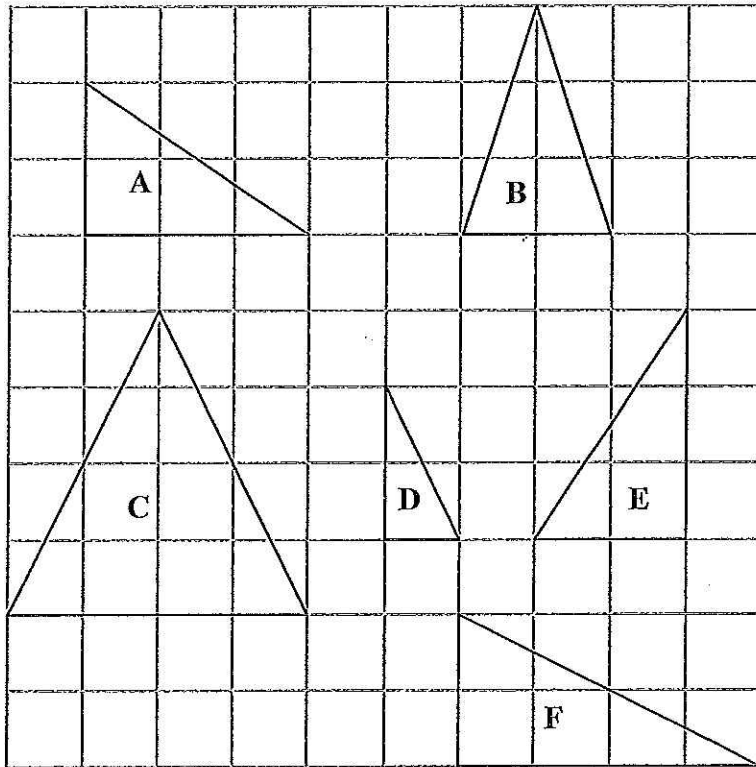

Two of the triangles are congruent.

(a) Write down the letters of these two triangles.

..... A and E
(1)

One of the triangles is an enlargement of another of the triangles.

(b) Write down the letters of these two triangles.

..... D and F
(1)

Two of the triangles each have one line of symmetry.

(c) Write down the letters of these two triangles.

..... B and C
(1)

(Total 3 marks)

Q10



11.

Evens	Unlikely	Impossible	Certain	Likely
-------	----------	------------	---------	--------

Use a word from the box which best describes each of the following events.

(a) When you throw an ordinary dice you get a number greater than 1

Likely.....
(1)

(b) When you throw an ordinary coin you get a head.

Evens.....
(1)

(c) When you take out a counter from a bag that contains only blue counters you get a red counter.

Impossible.....
(1)

(Total 3 marks)

Q11

12. A tin of paint costs £4.87
Helen buys 19 tins of paint.

Work out an estimate for the total cost.

$$= 5 \times 20 = 100$$

£ 100.....

(Total 2 marks)

Q12



13. (a) On the centimetre grid draw a **rectangle** with an area of 20 cm^2 .

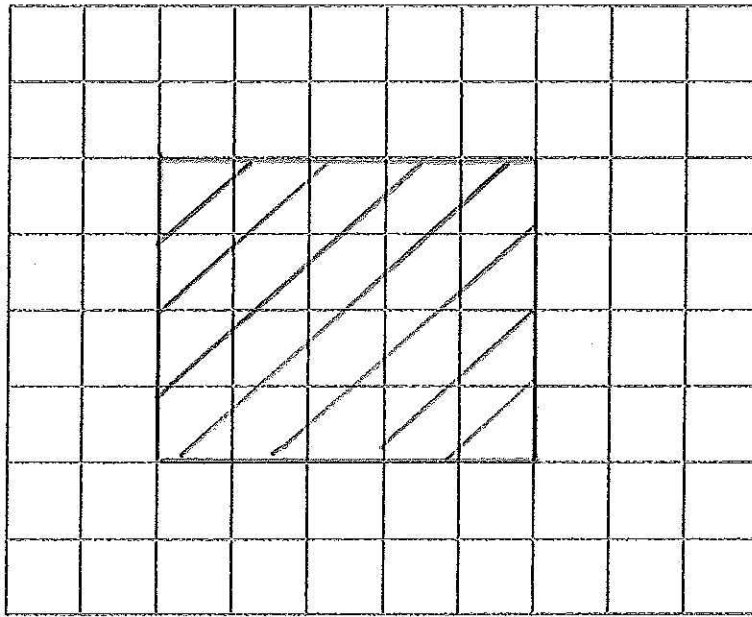

(2)

(b) On the centimetre grid draw an **isosceles** triangle with an area of 12 cm^2 .

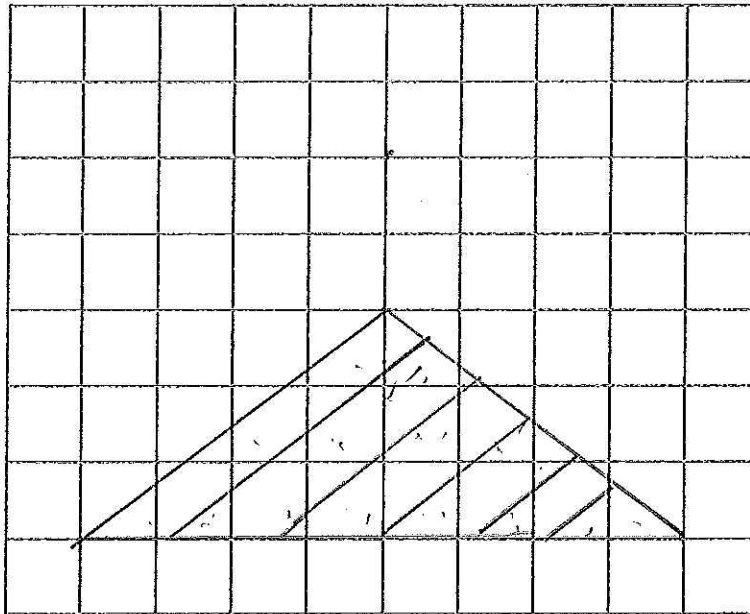

(2)

Q13

(Total 4 marks)



14. $x = 5$ and $y = \frac{1}{2}$.

Work out the value of

(i) $4x + 2y$

$$(4 \times 5) + (2 \times \frac{1}{2})$$

$$20 + 1$$

.....21.....

(ii) $10 - x^2$

$$10 - 5^2$$

$$10 - 25$$

.....-15.....

(Total 3 marks)

Q14

15. (a) Work out $564 - 128$

$$\begin{array}{r} 564 \\ -128 \\ \hline 436 \end{array}$$

.....436.....

(2)

(b) Work out $4 \times 7 \times 5$

$$4 \times 7 = 28$$

$$28 \times 5 = 140$$

$$5 \times 8 = 40$$

$$\begin{array}{r} 20 \times 5 = 100 \\ \hline 140 \end{array}$$

.....140.....

(2)

(Total 4 marks)

Q15



16. (a) This shape has rotational symmetry.

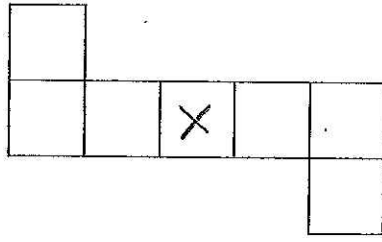

Mark with a cross (X) the centre of rotation.

(1)

(b)

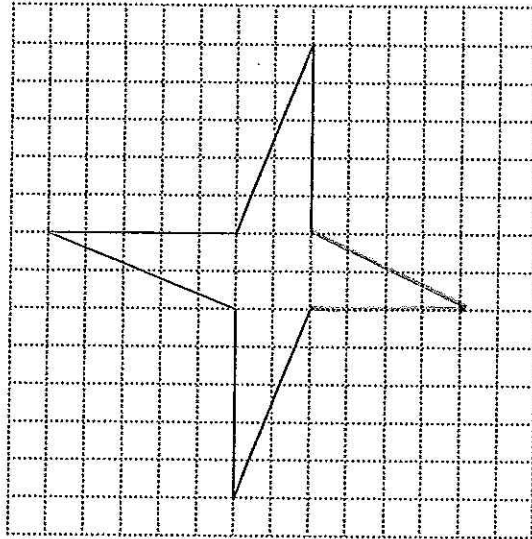

Complete this shape so that it has rotational symmetry of order 4

(1)

Q16

(Total 2 marks)



17.

Reading				
22	Slough			
28	40	Guildford		
30	22	47	Oxford	
45	28	66	25	Buckingham

The table gives distances in miles by road between some towns.

(a) Write down the distance between Reading and Guildford.

.....28..... miles
(1)

Sophie drives from Slough to Guildford.
She then drives from Guildford to Reading.
Sophie then drives from Reading to Slough.

(b) Work out the total distance that she drives.

$$\begin{array}{r}
 40 \\
 + 28 \\
 + 22 \\
 \hline
 90
 \end{array}$$

.....90..... miles
(2)



Izzy lives in Oxford.

She has to drive to a meeting in Buckingham and then from Buckingham to Reading to pick up a friend.

After she picks up her friend she will drive back to Oxford.

She plans to drive at a speed of 50 miles per hour.

The meeting will last 3 hours, including lunch.

She leaves Oxford at 9 am.

(c) Work out the time at which she should get back to Oxford.

$$\begin{array}{r} 25 \\ 45 \\ 30 \\ \hline 100 \end{array}$$

$$100 \div 50 = 2$$

$$2 + 3 = 5$$

11:00

(4)

Q17

(Total 7 marks)

18. Jim has £x.

Gemma has £4 more than Jim.

Jo has £2 less than Jim.

The total amount of money they have is £23

(a) Use this information to write down an equation in x.

$$x + x + 4 + x - 2 = 23$$

(2)

(b) Solve the equation to find how much money Jim has.

$$x + x + 4 + x - 2 = 23$$

$$-2(3x + 2 = 23) - 2$$

$$\div 3(3x = 21) \div 3$$

$$x = 7$$

£ 7

(2)

Q18

(Total 4 marks)



19. Theo earns £20 one weekend.
He gives £4 to his brother.

- (a) Express £4 as a fraction of £20
Give your answer in its simplest form.

$$\frac{4}{20}$$

(2)

Theo gives £6 to his mother.

- (b) Express £6 as a percentage of £20

$$\frac{6}{20} \overset{\times 5}{=} \frac{30}{100}$$

$$30\%$$

(2)

Theo spent the remaining £10 on bus fares and food.
He spent £1.50 more on bus fares than on food.

- (c) How much did he spend on bus fares?

$$10 - 1.50 = 8.50$$

$$8.50 \div 2 = 4.25$$

$$4.25 + 1.50 = 5.75$$

$$£ 5.75$$

(2)

Q19

(Total 6 marks)



20. Here is a number pattern.

Line Number			
1	$1^2 + 3^2$	$2 \times 2^2 + 2$	10
2	$2^2 + 4^2$	$2 \times 3^2 + 2$	20
3	$3^2 + 5^2$	$2 \times 4^2 + 2$	34
4	$4^2 + 6^2$	$2 \times 5^2 + 2$	52
10	$10^2 + 12^2$	$2 \times 11^2 + 2$	244

(a) Complete Line Number 4 of the pattern.

(1)

(b) Complete Line Number 10 of the pattern.

(2)

(c) Use the number pattern to find the answer to $999^2 + 1001^2$

$$2 \times 1000^2 + 2$$

$$2000002$$

(2)

Q20

(Total 5 marks)



21. Jim did a survey on the lengths of caterpillars he found on a field trip.

Information about the lengths is given in the stem and leaf diagram.

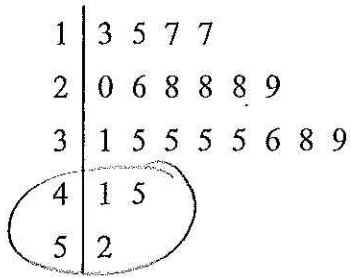

Key: 5|2 means 5.2 cm

(a) Find the range.

$$\begin{array}{r} 5.2 \\ - 1.3 \\ \hline 3.9 \end{array}$$

..... 3.9 cm
(2)

(b) Work out the median.

..... 3.1 cm
(2)

A caterpillar is chosen at random from these caterpillars.

(c) Find the probability that this caterpillar is longer than 4 cm.

$$\frac{3}{21}$$

..... $\frac{3}{21}$
(2)

(Total 6 marks)

Q21



22. (a) Expand and simplify

$$2(x-y) - 3(x-2y)$$

$$2x - 2y - 3x + 6y$$

$$-x + 4y$$

$$\underline{-x + 4y} \quad (2)$$

(b) Solve

$$3y + 12 = y + 8$$

$$-y \quad (2y + 12 = 8) \quad -y$$

$$-12 \quad (2y = -4) \quad -12$$

$$\div 2 \quad (y = -2) \quad \div 2$$

$$y = \underline{-2} \quad (2)$$

(c) Factorise

$$4 + 6x$$

$$\underline{2(2 + 3x)} \quad (1)$$

(Total 5 marks)

Q22



23.

Diagram NOT accurately drawn

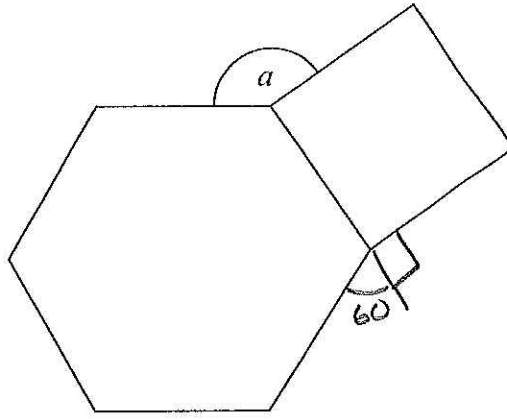

The diagram shows a regular hexagon and a square.

Calculate the size of the angle a .

$$360 \div 6 = 60$$

$$60 + 90 = 150$$

150 °

(Total 4 marks)

Q23



24. Suzy did an experiment to study the times, in minutes, it took 1 cm ice cubes to melt at different temperatures.
Some information about her results is given in the scatter graph.

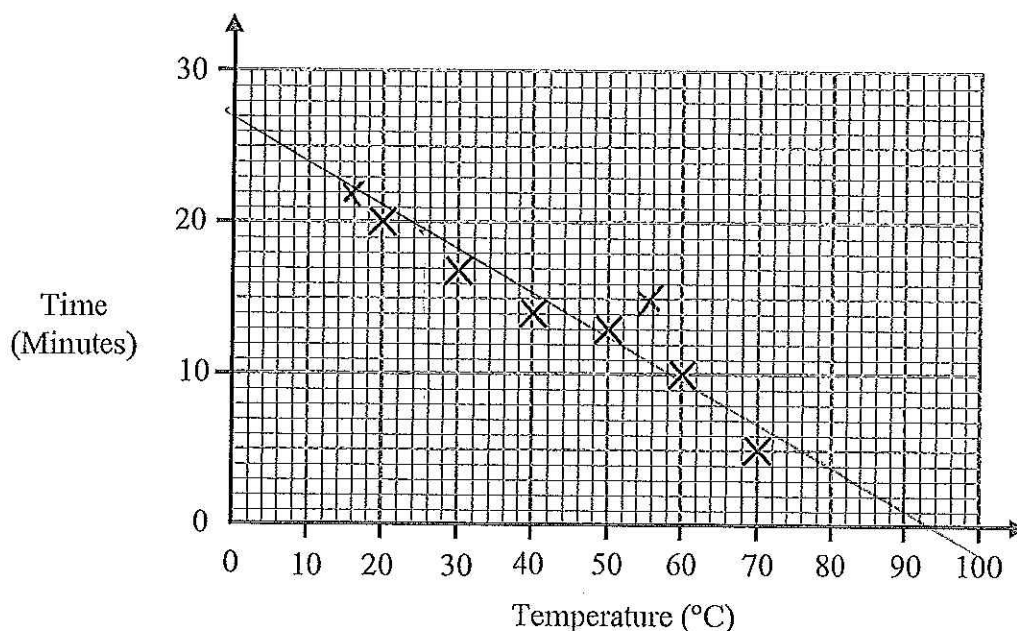

The table shows information from two more experiments.

Temperature (°C)	15	55
Time (Minutes)	22	15

- (a) On the scatter graph, plot the information from the table. (1)

- (b) Describe the relationship between the temperature and the time it takes a 1 cm ice cube to melt.

If the temperature increases the ice melted quicker. (1)

- (c) Find an estimate for the time it takes a 1 cm ice cube to melt when the temperature is 25 °C.

20 minutes (2)

Suzy's data cannot be used to predict how long it will take a 1 cm ice cube to melt when the temperature is 100 °C.

- (d) Explain why.

because 100°C would be negative time. (1)

(Total 5 marks)

Q24



25.

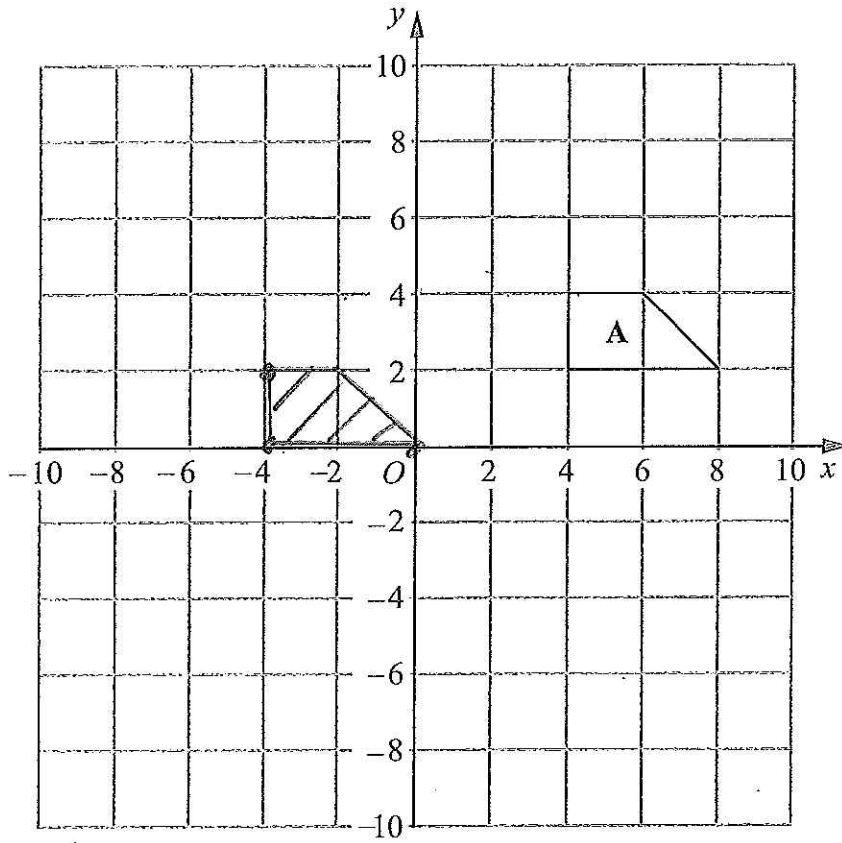

- (a) Translate shape A by $\begin{pmatrix} -8 \\ -2 \end{pmatrix}$
 Label the new shape **B**.

(2)



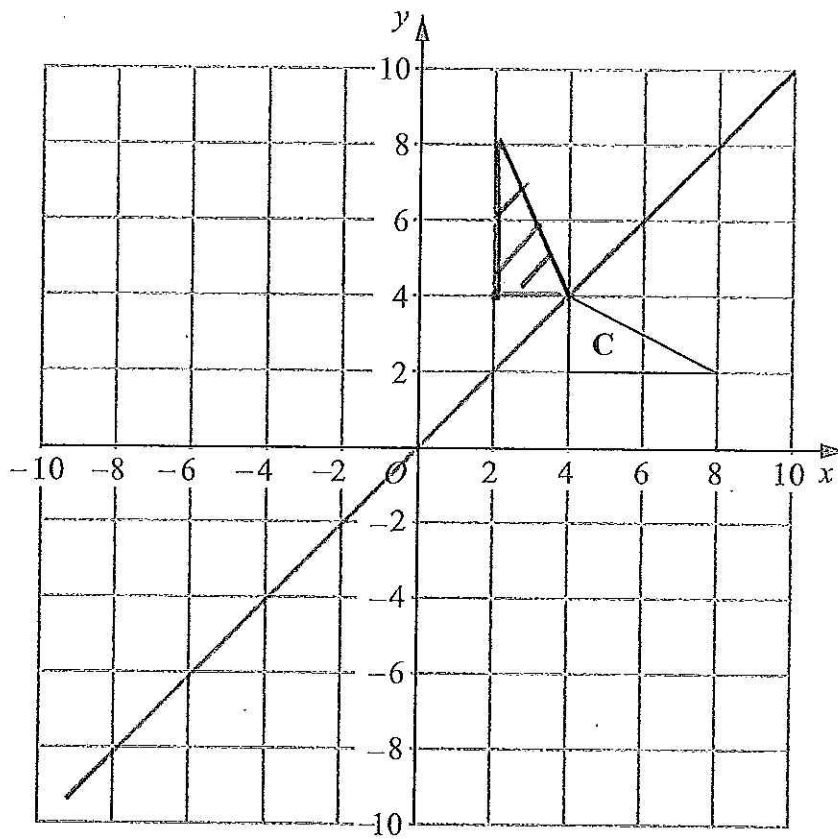

- (b) Reflect shape **C** in the line $y = x$.
Label the new shape **D**.

(2)

Q25

(Total 4 marks)

TOTAL FOR PAPER: 100 MARKS

END



BLANK PAGE



BLANK PAGE



BLANK PAGE

