

| | | | | | | | | |
|---------------|--|--|--|--|--|-----------------|-----------|------------|
| Centre No. | | | | | | Paper Reference | Surname | Initial(s) |
| Candidate No. | | | | | | 1 3 8 0 / 4 H | Signature | |

Paper Reference(s)

1380/4H

Edexcel GCSE

Mathematics (Linear) – 1380

Paper 4 (Calculator)

Higher Tier

Friday 12 November 2010 – Morning

Time: 1 hour 45 minutes

Examiner's use only

| | | |
|--|--|--|
| | | |
|--|--|--|

Team Leader's use only

| | | |
|--|--|--|
| | | |
|--|--|--|



Materials required for examination

Ruler graduated in centimetres and millimetres, protractor, compasses, pen, HB pencil, eraser, calculator. Tracing paper may be used.

Items included with question papers

Nil

Instructions to Candidates

In the boxes above, write your centre number, candidate number, your surname, initials and signature. Check that you have the correct question paper. Answer ALL the questions. Write your answers in the spaces provided in this question paper. You must NOT write on the formulae page. Anything you write on the formulae page will gain NO credit. If you need more space to complete your answer to any question, use additional answer sheets.

Information for Candidates

The marks for individual questions and the parts of questions are shown in round brackets: e.g. (2). There are 28 questions in this question paper. The total mark for this paper is 100. There are 28 pages in this question paper. Any blank pages are indicated. Calculators may be used.

If your calculator does not have a π button, take the value of π to be 3.142 unless the question instructs otherwise.

Advice to Candidates

Show all stages in any calculations. Work steadily through the paper. Do not spend too long on one question. If you cannot answer a question, leave it and attempt the next one. Return at the end to those you have left out.

This publication may be reproduced only in accordance with Edexcel Limited copyright policy. ©2010 Edexcel Limited.

Printer's Log No.

N37834A

W850/R5540H/57570 6/6/6/6/c6



Turn over

edexcel 
advancing learning, changing lives

GCSE Mathematics (Linear) 1380

Formulae: Higher Tier

You must not write on this formulae page.
Anything you write on this formulae page will gain NO credit.

Volume of a prism = area of cross section \times length

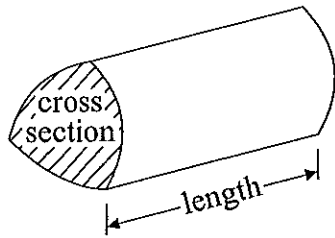

Volume of sphere = $\frac{4}{3}\pi r^3$

Surface area of sphere = $4\pi r^2$

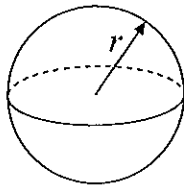

Volume of cone = $\frac{1}{3}\pi r^2 h$

Curved surface area of cone = $\pi r l$

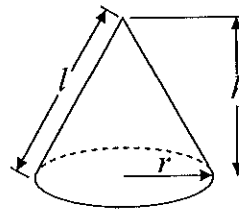

In any triangle ABC

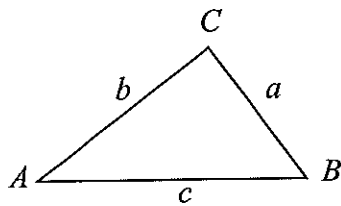

The Quadratic Equation

The solutions of $ax^2 + bx + c = 0$

where $a \neq 0$, are given by

$$x = \frac{-b \pm \sqrt{b^2 - 4ac}}{2a}$$

Sine Rule $\frac{a}{\sin A} = \frac{b}{\sin B} = \frac{c}{\sin C}$

Cosine Rule $a^2 = b^2 + c^2 - 2bc \cos A$

Area of triangle = $\frac{1}{2} ab \sin C$



Answer ALL TWENTY EIGHT questions.

Write your answers in the spaces provided.

You must write down all stages in your working.

1.

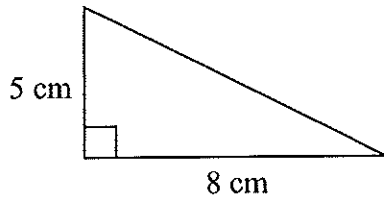

Diagram NOT accurately drawn

Work out the area of this right-angled triangle.

$$\frac{\text{base} \times \text{height}}{2} = \frac{8 \times 5}{2} = \frac{40}{2} = 20 \text{ cm}^2$$

..... 20 cm²
(Total 2 marks)

Q1

2. A spinner can land on red or blue or pink.
The table shows the probabilities that the spinner will land on red or on blue.

| | | | |
|-------------|------|------|------|
| Colour | red | blue | pink |
| Probability | 0.58 | 0.30 | |

Work out the probability that the spinner will land on pink.

$$1 - 0.58 - 0.30 = 0.12$$

..... 0.12
(Total 2 marks)

Q2



3. There are 20 beads in box A.

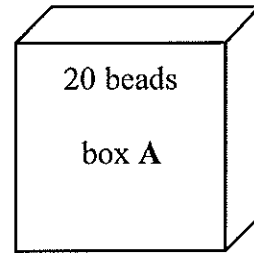

In box B there are twice as many beads as in box A.

$$2 \times 20 = 40$$

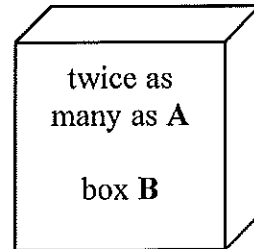

In box C there are $\frac{3}{4}$ of the number of beads as in box A.

$$\frac{3}{4} \text{ of } 20 = 15$$

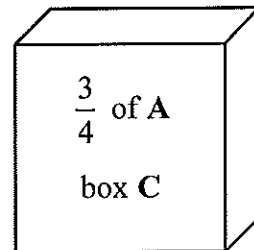

In box D there are 10% more beads than in box A.

$$10\% \text{ of } 20 = 2$$

$$20 + 2 = 22$$

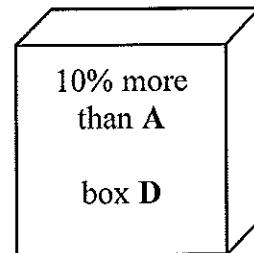

Work out the total number of beads in the four boxes.

$$\begin{array}{r} 20 \\ + 40 \\ + 15 \\ + 22 \\ \hline 97 \end{array}$$

97 beads

(Total 4 marks)

Q3



4. Here is a list of ingredients to make melon sorbet for 6 people.

| Melon Sorbet for 6 people | |
|------------------------------|--------------|
| 800 g | melon |
| 4 | egg whites |
| $\frac{1}{2}$ | lime |
| 100 g | caster sugar |

Terry makes melon sorbet for 18 people.

(a) Work out how much caster sugar he uses.

6 people $\xrightarrow{\times 3}$ 18 people
 $100 \times 3 = 300$

..... 300 g
 (2)

Hedley makes melon sorbet.
 He uses 2 limes.

(b) Work out how many people he makes melon sorbet for.

$\frac{1}{2}$ lime $\xrightarrow{\times 4}$ 2 limes
 $6 \times 4 = 24$

..... 24
 (2)

(Total 4 marks)

Q4



5.

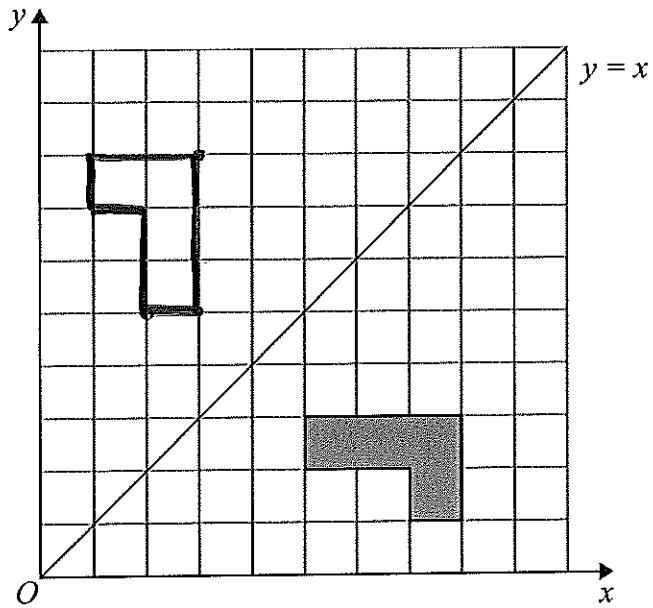

(a) Reflect the shaded shape in the line $y = x$.

(2)

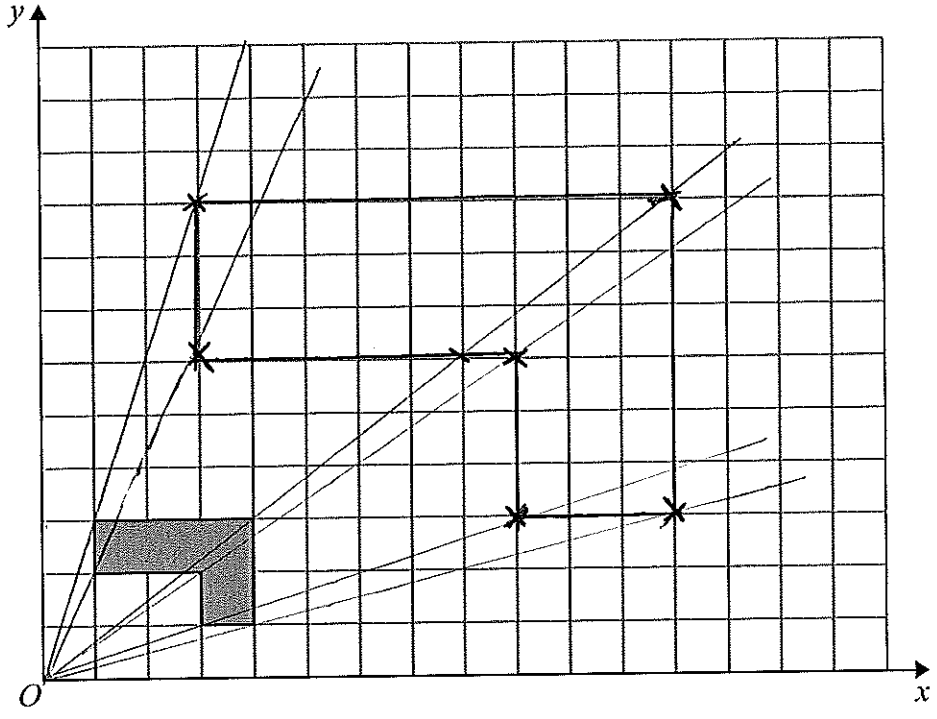

(b) On the grid, enlarge the shaded shape by a scale factor of 3, centre O .

(3)

(Total 5 marks)

Q5



6. (a) Simplify $7x + 2y - x + 3y$

$$\underline{6x + 5y} \quad (2)$$

(b) Solve $2x + 3 = 10$

$$2x = 10 - 3$$

$$2x = 7$$

$$x = \frac{7}{2} = 3.5$$

$$x = \underline{3.5} \quad (2)$$

(c) Simplify

(i) $c^5 \times c^6$

$$\underline{c^{11}}$$

(ii) $e^{12} \div e^4$

$$\underline{12^8} \quad (2)$$

(Total 6 marks)

Q6

7. Noah got 8 out of 20 in a test.

Write 8 out of 20 as a percentage.

$$\frac{8}{20} = \frac{40}{100}$$

$$\underline{40} \% \quad (2)$$

(Total 2 marks)

Q7



8. The table shows some information about the ages, in years, of 60 people.

| Age (in years) | Frequency |
|----------------|-----------|
| 0 to 9 | 6 |
| 10 to 19 | 13 |
| 20 to 29 | 12 |
| 30 to 39 | 9 |
| 40 to 49 | 7 |
| 50 to 59 | 3 |
| 60 to 69 | 10 |

(a) Write down the modal class.

.....10 to 19.....
(1)

Luke says

'The median lies in the class 30 to 39'

Luke is wrong.

(b) Explain why.

The median is the 30th value which lies in the class '20 to 29'
(1)

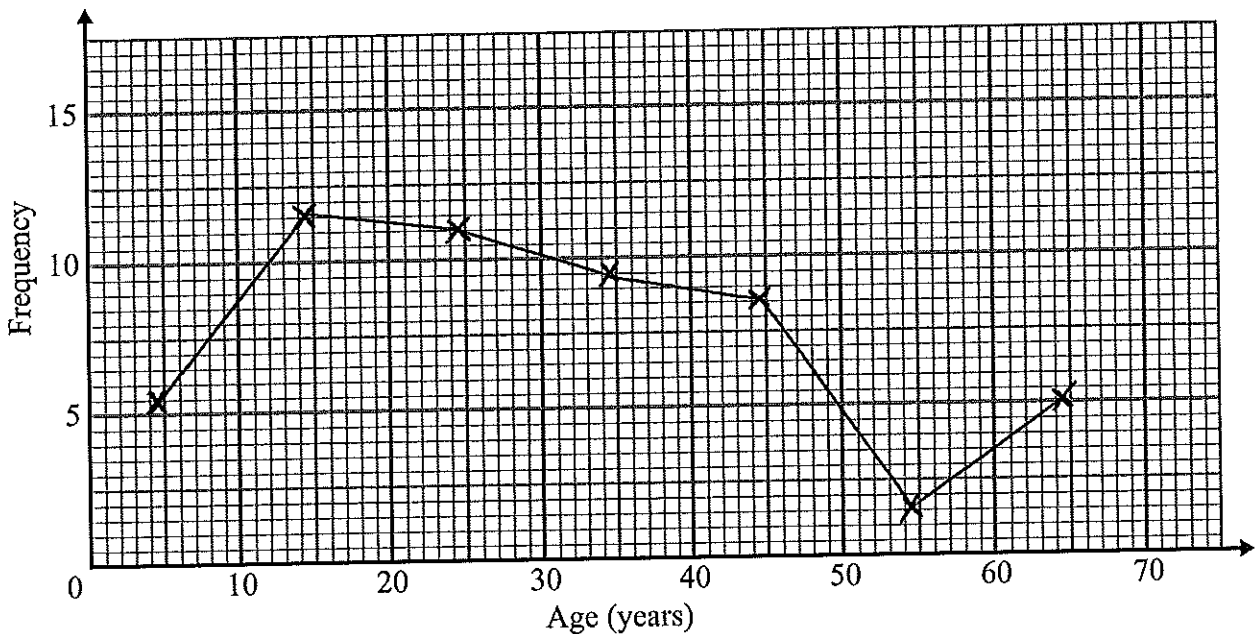

(c) On the grid, draw a frequency polygon for the information in the table.

(2)

(Total 4 marks)

Q8



9. Use your calculator to work out

$$\frac{13.7 + 5.86}{2.54 \times 3.17}$$

$$\frac{19.56}{8.0518}$$

Write down all the figures on your calculator display.
You must give your answer as a decimal.

$$\frac{19.56}{8.0518} = 2.429270474$$

$$\underline{2.429270474}$$

(Total 2 marks)

Q9

10. $-3 < k \leq 2$
 k is an integer.

(a) Write down all the possible values of k .

$$\underline{-2, -1, 0, 1, 2}$$

(2)

(b) Solve the inequality $\frac{2x}{3} < 10$

$$2x < 10 \times 3$$

$$2x < 30$$

$$x < \frac{30}{2}$$

$$\underline{x < 15}$$

(2)

(Total 4 marks)

Q10

$$x < 15$$



11. Here are four containers.
Water is poured into each container at a constant rate.

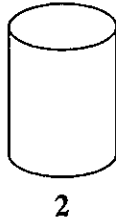

Here are four graphs.
The graphs show how the depth of the water in each container changes with time.

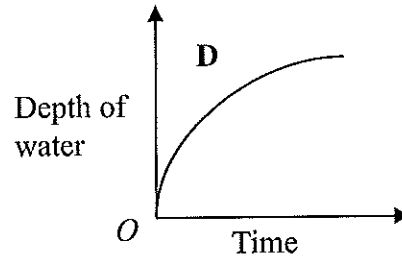
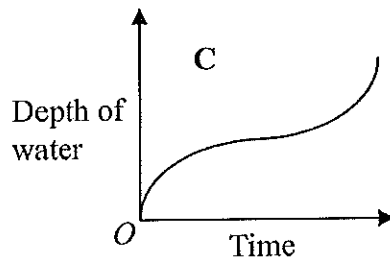
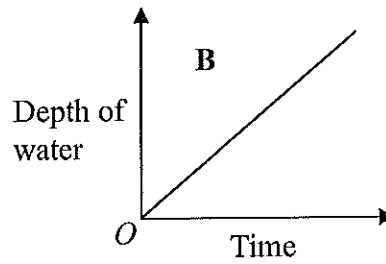
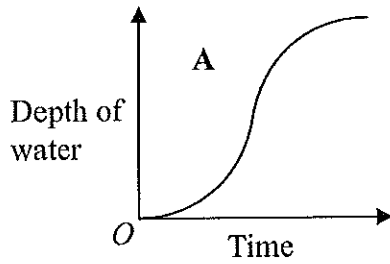

Match each graph with the correct container.

A and3.....

B and2.....

C and4.....

D and1.....

(Total 2 marks)

Q11



12. A shop sells small boxes and large boxes for storing CDs.

A small box stores x CDs.
A large box stores y CDs.

Ethan buys 7 small boxes.
He also buys 5 large boxes.

Ethan can store a total of T CDs in these boxes.

Write down a formula for T in terms of x and y .

CDs from small boxes = $7 \times x = 7x$
 CDs from large boxes = $5 \times y = 5y$
 Total CDs = $7x + 5y$
 $T = 7x + 5y$
 (Total 3 marks)

Q12

13. A family went on holiday to Miami.
They travelled from London by plane.

The distance from London to Miami is 7120 km.
The plane journey took 8 hours.

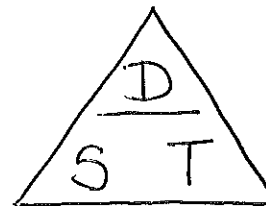

Calculate the average speed of the plane.

Speed = $\frac{\text{Distance}}{\text{Time}}$
 $\text{Speed} = \frac{7120}{8} = 890 \text{ km/h}$
 890 km/h
 (Total 2 marks)

Q13



14. The diagram shows a solid prism made from centimetre cubes.

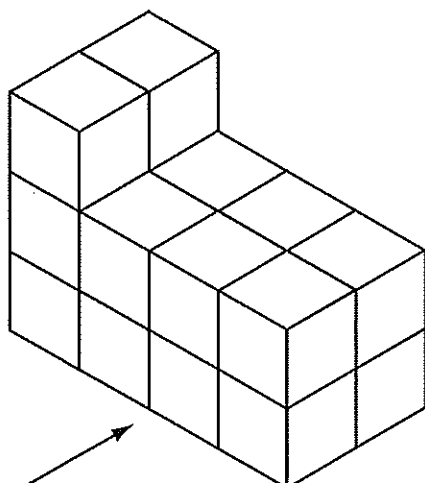

- (a) On the centimetre square grid, draw the front elevation of the solid prism from the direction shown by the arrow.

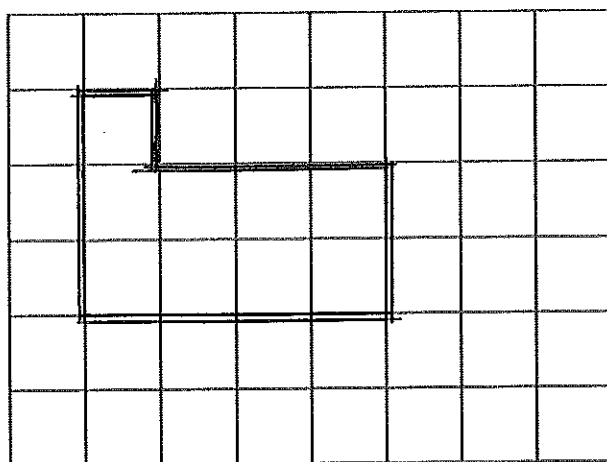

(2)

- (b) On the centimetre square grid below, draw the plan of the solid prism.

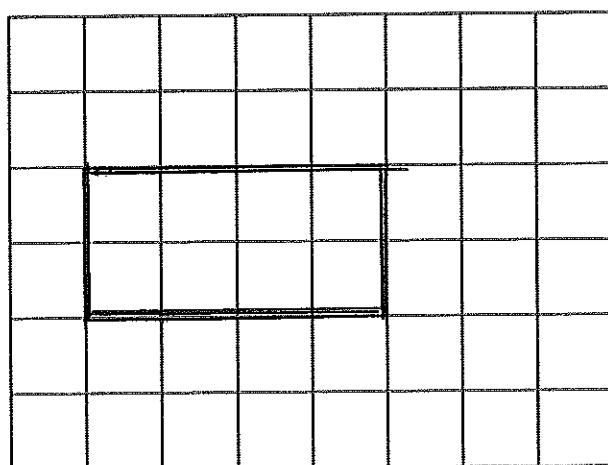

(2)

(Total 4 marks)

Q14



15. 200 students in Year 11 took a mathematics test.
Kamini wants to find out whether students in Year 11 like mathematics.

For her sample she asks the 20 students who got the highest marks in the test.

This is **not** a good sample to use.

(a) Write down **one** reason why.

Biased sample, student who are good at maths might tend to like maths more

(1)

She uses this question on her questionnaire.

| | | |
|-----------------------------------|--------------------------|--------------------------|
| What do you think of mathematics? | | |
| <input type="checkbox"/> | <input type="checkbox"/> | <input type="checkbox"/> |
| Excellent | Very good | Good |

(b) Write down **one** thing that is wrong with this question.

There is no option for a negative response

(1)

Kamini also wants to find out how many hours students spend on their mathematics homework.

(c) Design a suitable question that Kamini could use on her questionnaire.
You must include some response boxes.

How many hours do you spend on your homework each week?

| | | | |
|--------------------------|--------------------------|--------------------------|--------------------------|
| <input type="checkbox"/> | <input type="checkbox"/> | <input type="checkbox"/> | <input type="checkbox"/> |
| 0-1 hours | 2-3 hours | 4-5 hours | 6+ hours. |

(2)

(Total 4 marks)

Q15



16. G and H are vertices of a cuboid.

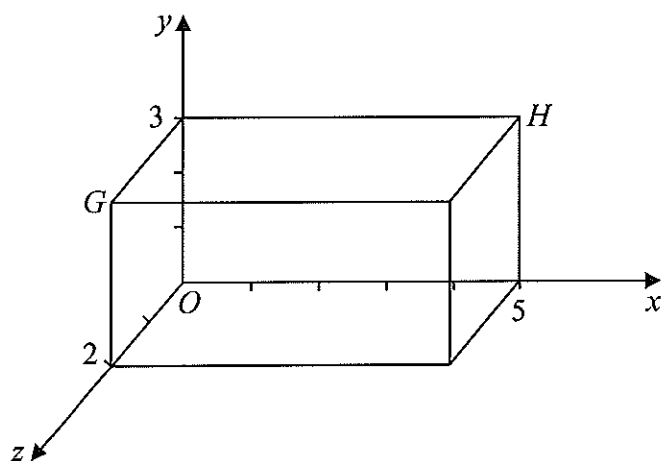

Diagram NOT accurately drawn

(a) Write down the coordinates of point G .

(0, 3, 2)
 (.....,,)
 (1)

(b) Write down the coordinates of point H .

(5, 3, 0)
 (.....,,)
 (1)

(Total 2 marks)

Q16

17. (a) Write 82 500 000 in standard form.

8.25×10^7

 (1)

(b) Work out $(5.2 \times 10^{-7}) \times (2.8 \times 10^{-9})$

Give your answer in standard form.

1.456×10^{-15}

 (2)

(Total 3 marks)

Q17



18.

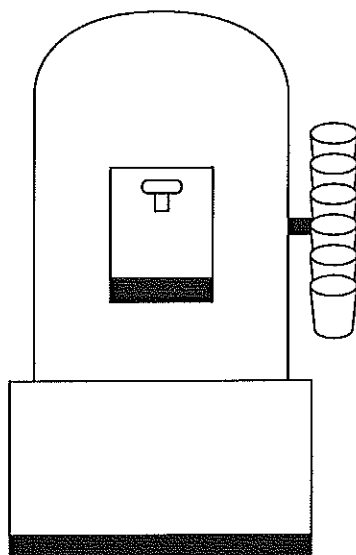

A water container has 19.5 litres of water in it.
A cup holds 210 ml of water.

At most 92 cups can be filled completely from the water container.
Explain why.
You must show all your working.

$$19.5 \text{ litres} = 19500 \text{ ml}$$

$$\frac{19500}{210} = 92.857142$$

\therefore 92 cups can be filled completely.

Q18

(Total 3 marks)



19. There are 100 teachers at Maria's school. Maria found out the age of each teacher.

The table gives information about her results.

| Age (A years) | Frequency |
|------------------|-----------|
| $20 < A \leq 30$ | 26 |
| $30 < A \leq 40$ | 35 |
| $40 < A \leq 50$ | 21 |
| $50 < A \leq 60$ | 12 |
| $60 < A \leq 70$ | 6 |

(a) Complete the cumulative frequency table.

| Age (A years) | Cumulative Frequency |
|------------------|----------------------|
| $20 < A \leq 30$ | 26 |
| $20 < A \leq 40$ | 61 |
| $20 < A \leq 50$ | 82 |
| $20 < A \leq 60$ | 94 |
| $20 < A \leq 70$ | 100 |

(1)

(b) On the grid opposite, draw a cumulative frequency graph for your table.

(2)

(c) Use your graph to find an estimate for the median age.

.....36..... years
(1)

(d) Use your graph to find an estimate for the number of these teachers who are **older** than 56 years old.

$$100 - 90 = 10$$

.....10.....
(2)



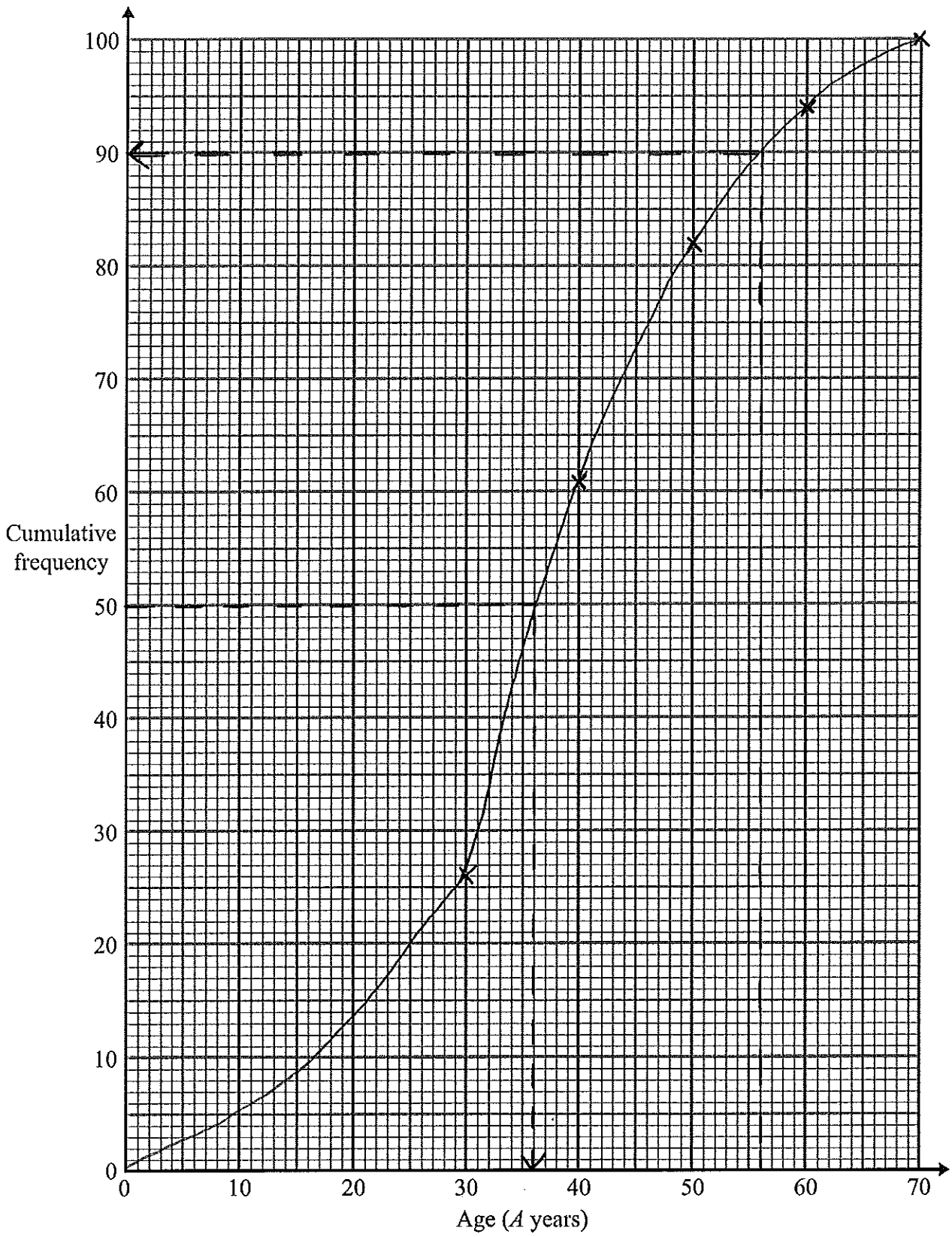

(Total 6 marks)

Q19



20. (a) Write 56 as a product of its prime factors.

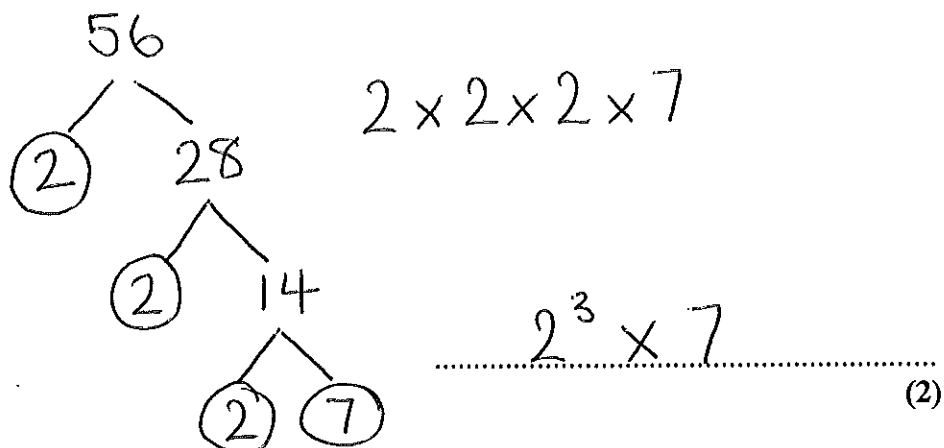

(b) Find the Highest Common Factor (HCF) of 56 and 42

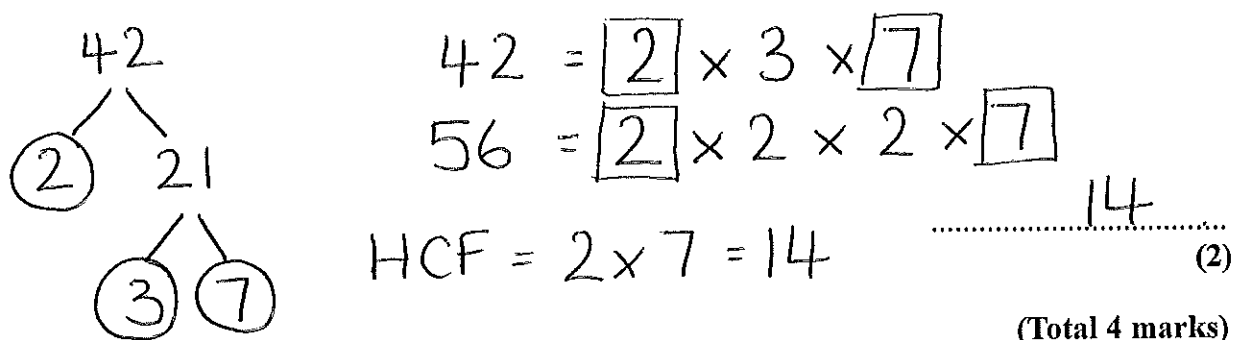

Q20

21.

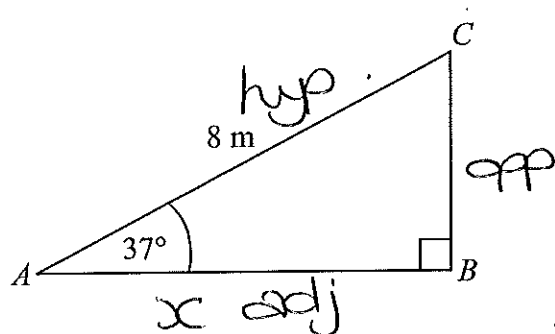

ABC is a right-angled triangle.
 $AC = 8 \text{ m}$.
Angle $CAB = 37^\circ$.

Calculate the length of AB .
Give your answer correct to 3 significant figures.

Diagram NOT accurately drawn

$$\sin x = \frac{\text{opp}}{\text{hyp}} \quad \cos x = \frac{\text{adj}}{\text{hyp}}$$

$$\tan x = \frac{\text{opp}}{\text{adj}}$$

$$\cos 37 = \frac{x}{8}$$

$$x = 8 \times \cos 37$$

$$= 6.39 \text{ cm (3 sf)}$$

..... 6.39 m
(Total 3 marks)

Q21



22. (a) Complete the table of values for $y = x^3 - 7$

| | | | | | | |
|-----|-----|----|----|----|---|----|
| x | -2 | -1 | 0 | 1 | 2 | 3 |
| y | -15 | -8 | -7 | -6 | 1 | 20 |

(2)

(b) On the grid, draw the graph of $y = x^3 - 7$ for values of x from -2 to 3

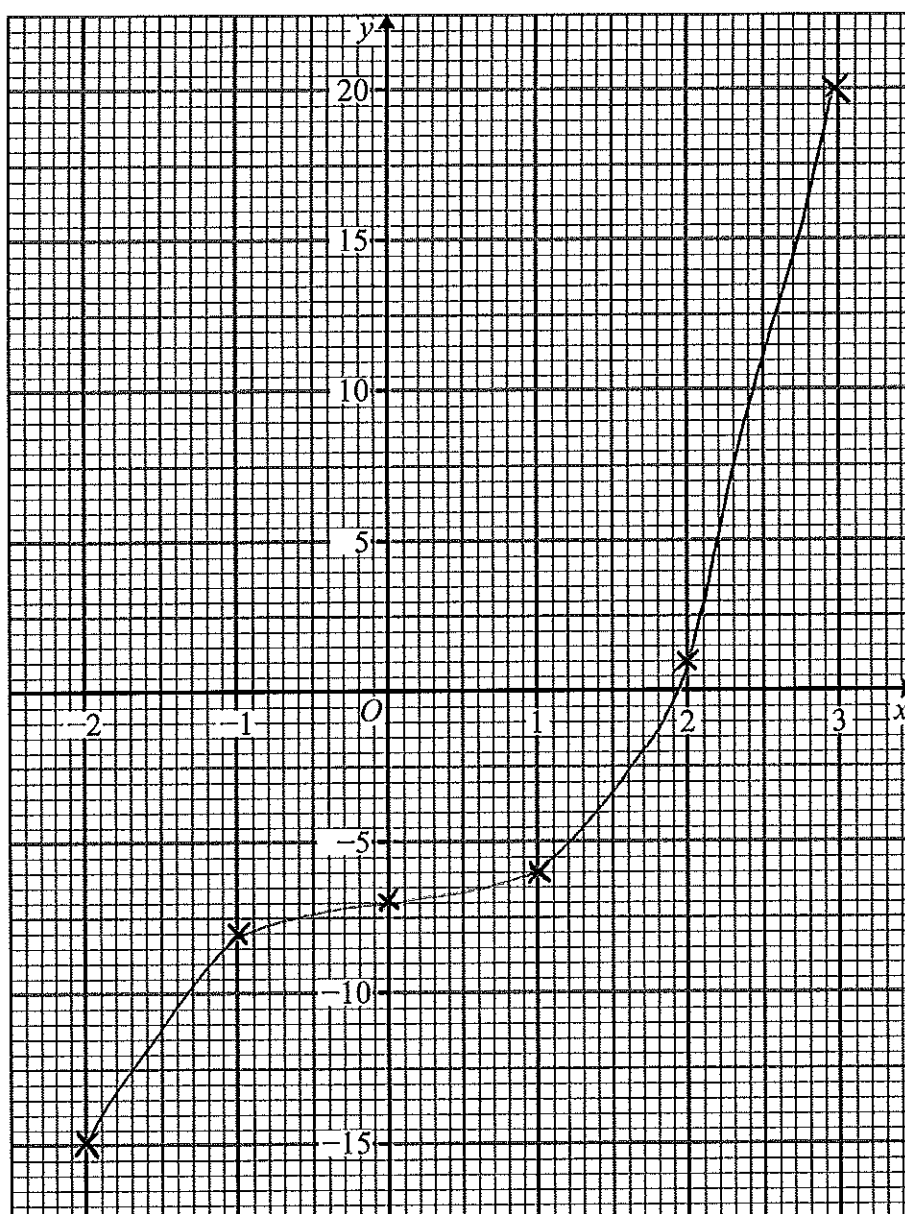

(2)

(Total 4 marks)

Q22



23.

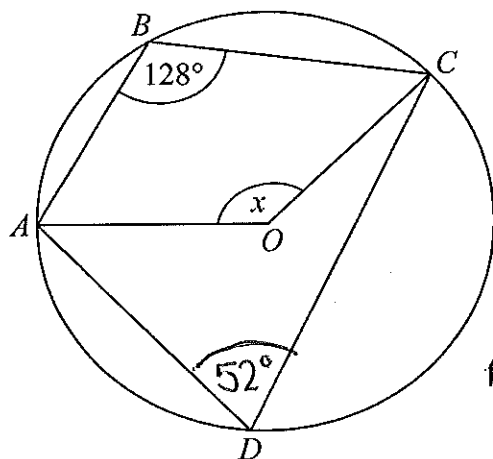

Diagram NOT accurately drawn

ABCD is a cyclic quadrilateral. \therefore
 Angle ADC = $180 - 128$
 $= 52$

The diagram shows a circle, centre O .
 A, B, C and D are points on the circumference of the circle.

Angle $ABC = 128^\circ$.

Work out the size of the angle marked x .

Angles at the centre are twice the size of the angle at the circumference

$$\therefore x = 52 \times 2$$

$$= 104^\circ$$

.....104..... $^\circ$;

(Total 2 marks)

Q23

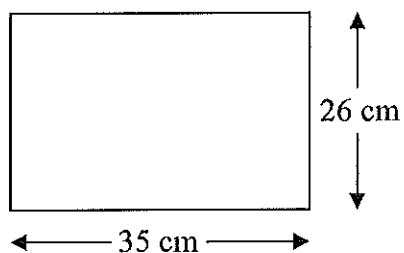

24.

Diagram **NOT**
accurately drawn

The length of the rectangle is 35 cm correct to the nearest cm.
The width of the rectangle is 26 cm correct to the nearest cm.

Calculate the upper bound for the area of the rectangle.
Write down all the figures on your calculator display.

$$26.5 \times 35.5$$
$$= 940.75$$

$$\dots\dots\dots 940.75 \dots\dots\dots \text{cm}^2$$

(Total 3 marks)

Q24



25. (a) Expand and simplify $(2x + 4y)(4x - 5y)$

| | | |
|-----|-----------------|-------------------|
| | 4x | -5y |
| 2x | 8x ² | -10xy |
| +4y | +16xy | -20y ² |

$$8x^2 - 10xy + 16xy - 20y^2$$

$$\underline{\underline{8x^2 + 6xy - 20y^2}} \quad (2)$$

(b) Simplify fully $\frac{(x+10)^5}{(x+10)^4}$

$$\frac{\cancel{(x+10)}\cancel{(x+10)}\cancel{(x+10)}\cancel{(x+10)}\cancel{(x+10)}}{\cancel{(x+10)}\cancel{(x+10)}\cancel{(x+10)}\cancel{(x+10)}}$$

$$\underline{\underline{x+10}} \quad (1)$$

(c) Simplify fully $\frac{x^2 - 25}{x^2 + 7x + 10}$

$$\frac{\cancel{(x+5)}(x-5)}{(x+2)\cancel{(x+5)}}$$

$$\underline{\underline{\frac{x-5}{x+2}}} \quad (3)$$

For all values of x , $x^2 + 6x - 2 = (x + p)^2 + q$

(d) Find the value of p and the value of q .

$$(x + 3)^2 = x^2 + 6x + 9$$

$$(x + 3)^2 - 11 = x^2 + 6x - 2$$

| | | |
|----|----------------|-----|
| | x | +3 |
| x | x ² | +3x |
| +3 | +3x | +9 |

$$p = \dots 3 \dots \quad q = \dots -11 \dots \quad (2)$$

(Total 8 marks)

Q25



26. There are 11 buttons in a bag.

7 buttons are white.
4 buttons are black.

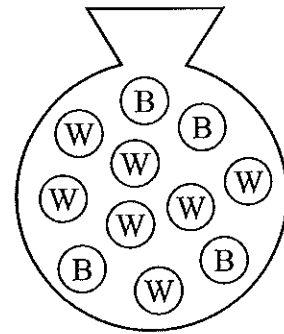

Harley takes a button at random from the bag, and keeps it.

She now takes another button at random from the bag.

Work out the probability that Harley takes a button of each colour.

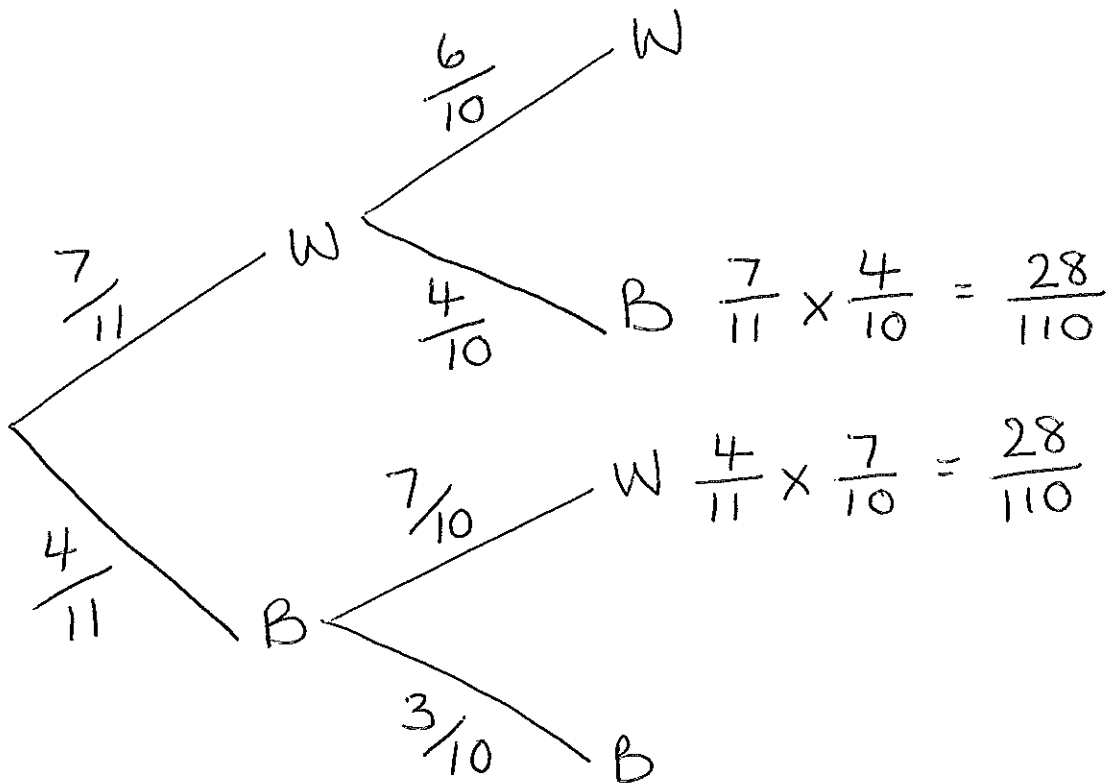

$$\frac{28}{110} + \frac{28}{110} = \frac{56}{110} = \frac{28}{55}$$

$$\frac{28}{55}$$

(Total 3 marks)

Q26



27. The graph of $y = f(x)$ is shown on the grids.

(a) On this grid, sketch the graph of $y = f(x - 3)$

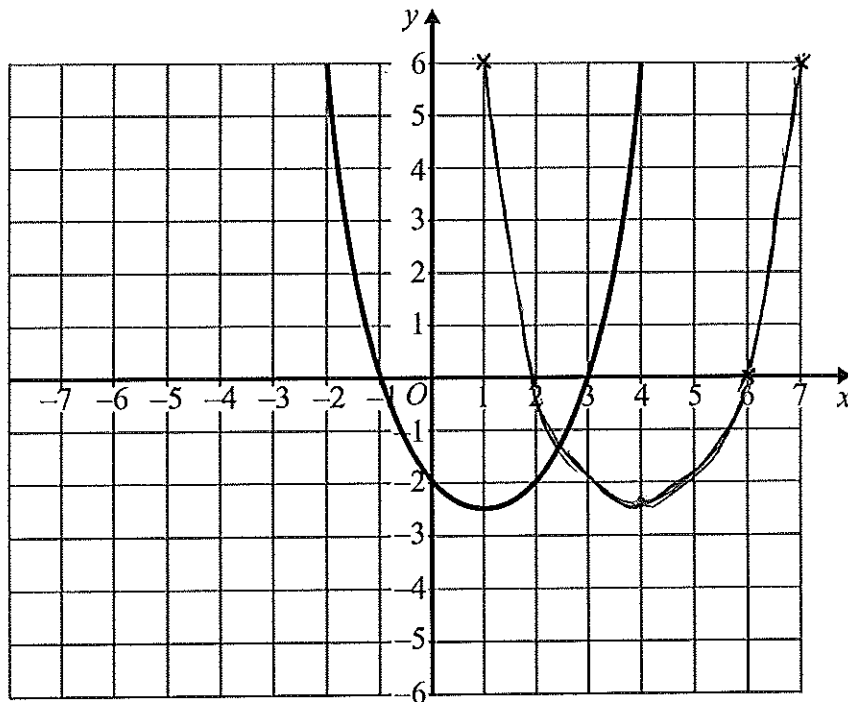

(2)

(b) On this grid, sketch the graph of $y = -f(x)$

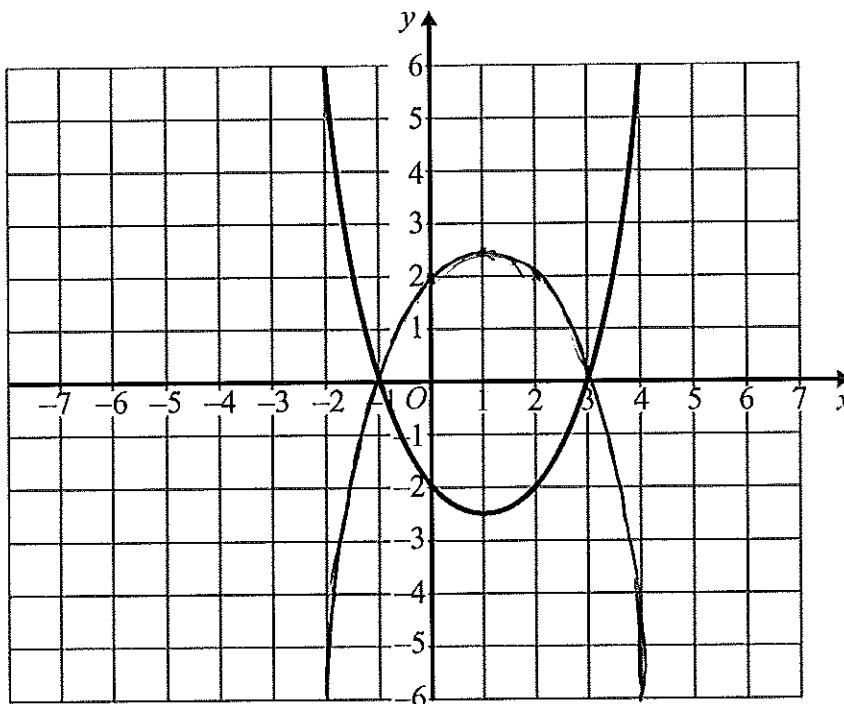

(2)

Q27

(Total 4 marks)

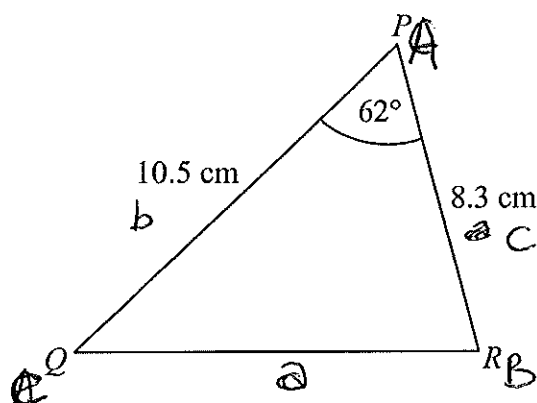

28.

Diagram NOT
accurately drawnIn triangle PQR ,

$$PQ = 10.5 \text{ cm,}$$

$$PR = 8.3 \text{ cm.}$$

$$\text{angle } QPR = 62^\circ.$$

(a) Calculate the area of triangle PQR .

Give your answer correct to 3 significant figures.

$$\text{Area} = \frac{1}{2} ab \sin C$$

$$\frac{1}{2} \times 8.3 \times 10.5 \times \sin 62$$

$$= 38.47444136$$

$$= 38.5 \text{ cm}^2 \text{ (3sf)}$$

$$\dots 38.5 \dots \text{ cm}^2 \text{ (2)}$$

(b) Calculate the length of QR .

Give your answer correct to 3 significant figures.

$$\text{Cosine Rule} = a^2 = b^2 + c^2 - 2bc \cos A$$

$$a^2 = 10.5^2 + 8.3^2 - (2 \times 10.5 \times 8.3 \times \cos 62)$$

$$a^2 = 97.31110661$$

$$a = \sqrt{97.31110661}$$

$$= 9.864639203$$

$$= 9.86 \text{ cm (3sf)}$$

$$\dots 9.86 \dots \text{ cm} \text{ (3)}$$

(Total 5 marks)

Q28

TOTAL FOR PAPER: 100 MARKS

END

