

Write your name here

Surname <b>BARTON</b>	Other names <b>CRAIG</b>
--------------------------	-----------------------------

Centre Number

Candidate Number

# Edexcel GCSE

# Mathematics A

## Paper 2 (Calculator)

**Higher Tier**

Friday 14 June 2013 – Morning <b>Time: 1 hour 45 minutes</b>	Paper Reference <b>1MA0/2H</b>
---	-----------------------------------

<b>You must have:</b> Ruler graduated in centimetres and millimetres, protractor, pair of compasses, pen, HB pencil, eraser, calculator. Tracing paper may be used.	Total Marks <b>100</b>
---	---------------------------

### Instructions

- Use **black** ink or ball-point pen.
- **Fill in the boxes** at the top of this page with your name, centre number and candidate number.
- Answer **all** questions.
- Answer the questions in the spaces provided – *there may be more space than you need.*
- **Calculators may be used.**
- If your calculator does not have a  $\pi$  button, take the value of  $\pi$  to be 3.142 unless the question instructs otherwise.



### Information

- The total mark for this paper is 100
- The marks for **each** question are shown in brackets – *use this as a guide as to how much time to spend on each question.*
- Questions labelled with an **asterisk** (\*) are ones where the quality of your written communication will be assessed.

### Advice

- Read each question carefully before you start to answer it.
- Keep an eye on the time.
- Try to answer every question.
- Check your answers if you have time at the end.

Turn over ►

P43600A

©2013 Pearson Education Ltd.  
6/5/5/



**PEARSON**

# GCSE Mathematics 1MA0

## Formulae: Higher Tier

**You must not write on this formulae page.  
Anything you write on this formulae page will gain NO credit.**

Volume of prism = area of cross section  $\times$  length

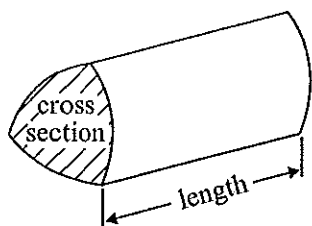

Area of trapezium =  $\frac{1}{2} (a + b)h$

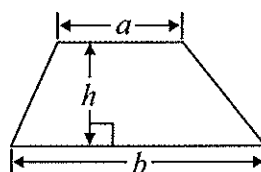

Volume of sphere =  $\frac{4}{3} \pi r^3$

Surface area of sphere =  $4\pi r^2$

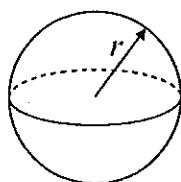

Volume of cone =  $\frac{1}{3} \pi r^2 h$

Curved surface area of cone =  $\pi r l$

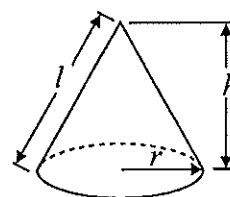

In any triangle  $ABC$

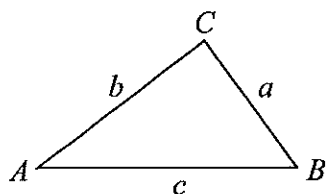

**The Quadratic Equation**

The solutions of  $ax^2 + bx + c = 0$   
where  $a \neq 0$ , are given by

$$x = \frac{-b \pm \sqrt{(b^2 - 4ac)}}{2a}$$

Sine Rule  $\frac{a}{\sin A} = \frac{b}{\sin B} = \frac{c}{\sin C}$

Cosine Rule  $a^2 = b^2 + c^2 - 2bc \cos A$

Area of triangle =  $\frac{1}{2} ab \sin C$



Answer ALL questions.

Write your answers in the spaces provided.

You must write down all stages in your working.

1 Here is a cuboid.

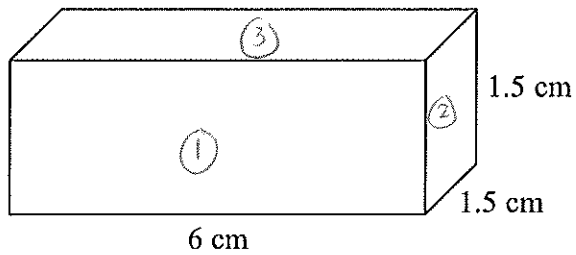

Diagram NOT accurately drawn

The cuboid is 6 cm by 1.5 cm by 1.5 cm.

Work out the total surface area of the cuboid.

$$\text{Area of } \textcircled{1} : 6 \times 1.5 = 9 \quad \checkmark$$

$$\text{Area of } \textcircled{2} : 1.5 \times 1.5 = 2.25 \quad \checkmark$$

$$\text{Area of } \textcircled{3} : 6 \times 1.5 = 9 \quad \checkmark$$

$$\underline{\underline{20.25}}$$

Two of each of these sides, so:

$$20.25 \times 2 = 40.5 \quad \checkmark$$

$$\dots\dots\dots 40.5 \dots\dots \text{cm}^2$$

(Total for Question 1 is 3 marks)



P 4 3 6 0 0 A 0 3 2 8

\*2 Here is a list of ingredients for making 18 mince pies.

**Ingredients for 18 mince pies**

225 g of butter  
350 g of flour  
100 g of sugar  
280 g of mincemeat  
1 egg

Elaine wants to make 45 mince pies.

Elaine has

1 kg of butter  
1 kg of flour  
500 g of sugar  
600 g of mincemeat  
6 eggs

Does Elaine have enough of each ingredient to make 45 mince pies?  
You must show clearly how you got your answer.

	B	F	S	M	E	
(18)	225	350	100	280	1	
(9)	112.5	175	50	140	0.5	✓
(45)	562.5	875	450	700	2.5	← Needs

Not enough mincemeat.

She has 600g but needs 700g

She does not have enough ingredients.

(Total for Question 2 is 4 marks)



- 3 The scatter graph shows some information about 10 cars, of the same type and make.  
The graph shows the age (years) and the value (£) of each car.

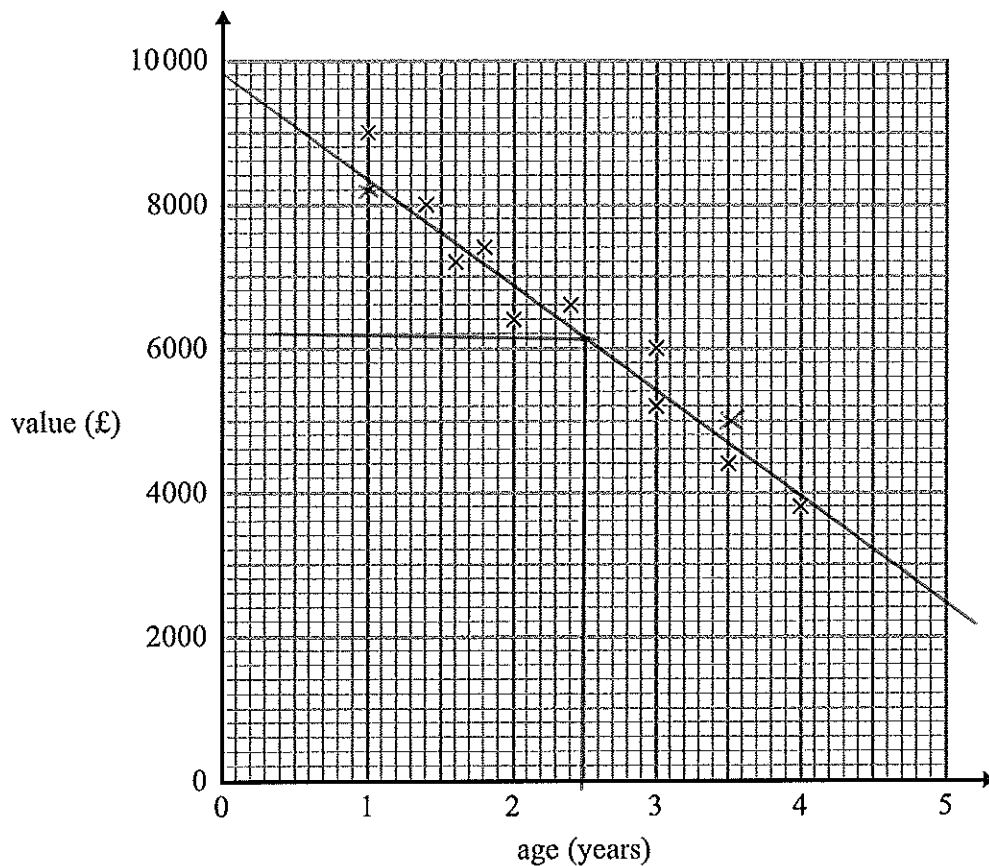

The table shows the age and the value of two other cars of the same type and make.

age (years)	1	3.5
value (£)	8200	5000

- (a) On the scatter graph, plot the information from the table.

(1)

- (b) Describe the relationship between the age and the value of the cars.

Older the car, lower the value

(Negative correlation)

(1)

A car of the same type and make is  $2\frac{1}{2}$  years old.

- (c) Estimate the value of the car.

£ 6200

(2)

(Total for Question 3 is 4 marks)



P 4 3 6 0 0 A 0 5 2 8

4 Rhiana plays a game.

The probability that she will lose the game is 0.32

The probability that she will draw the game is 0.05

Rhiana is going to play the game 200 times.

Work out an estimate for the number of times Rhiana will win the game.

$$\begin{aligned} \text{Prob (win)} &= 1 - 0.32 - 0.05 \\ &= 0.63 \end{aligned}$$

$$0.63 \times 200 = 126$$

126 times

(Total for Question 4 is 3 marks)



5 Mason is doing a survey to find out how many magazines people buy.

He uses this question on his questionnaire.

How many magazines do you buy?

<input type="text"/>	<input type="text"/>	<input type="text"/>
0 to 4	4 to 8	8 to 12

(a) Write down two things wrong with this question.

- 1 No time frame in question
- 2 Overlapping groups (response boxes)

(2)

(b) Write a better question for Mason to use on his questionnaire to find out how many magazines people buy.

How many magazines do you buy each month?

<input type="text"/>	<input type="text"/>	<input type="text"/>
0 to 4	5 to 8	9 or more

✓

(2)

Mason asks his friends at school to do his questionnaire.  
This may **not** be a good sample to use.

(c) Give one reason why.

- Biased sample as all likely to be  
Same age

(1)

(Total for Question 5 is 5 marks)



5

6 Tame Valley is a company that makes yoghurt.

A machine fills trays of 20 pots with yoghurt.

In one hour, the machine fills a total of 15 000 pots.

Work out how many seconds the machine takes to fill each tray of 20 pots.

$$1 \text{ hour} = 60 \times 60 = 3600 \text{ secs}$$

Fills 15,000 pots in 3600 secs

$$= \frac{15000}{3600} = 4.1\bar{6} \text{ pots per second}$$

$$\text{To fill 20 pots: } \frac{20}{4.1\bar{6}} = 4.8 \text{ secs}$$

..... 4.8 ..... seconds

(Total for Question 6 is 4 marks)





7 Colin, Dave and Emma share some money.

Colin gets  $\frac{3}{10}$  of the money.

Emma and Dave share the rest of the money in the ratio 3 : 2

What is Dave's share of the money?

Let full money = 100%

Colin gets 30%

Emma & Dave split 70%, 3:2

Emma : Dave  
3 : 2  
42% : 28%

$70 \div 5 = 14\%$   
 $2 \times 14 = 28\%$   
 $3 \times 14 = 42\%$

28%

(Total for Question 7 is 4 marks)



8 The diagram shows the plan of a playground.

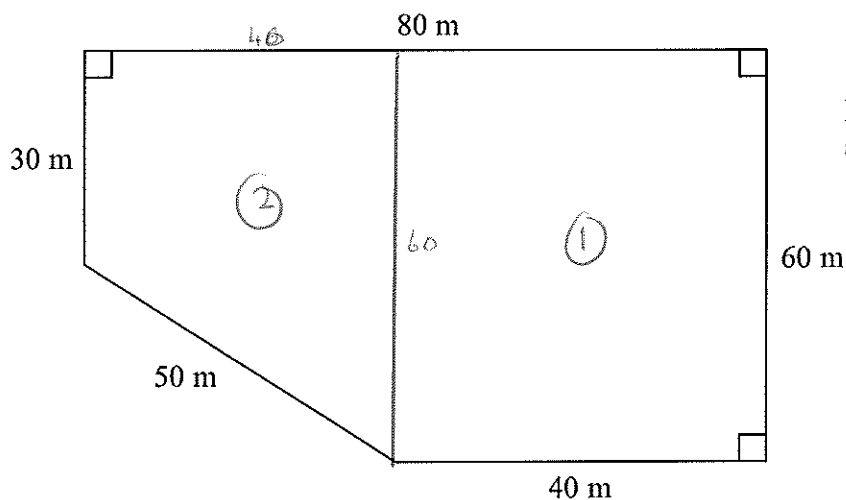

Bill is going to cover the playground with tarmac.  
It costs £2.56 to cover each square metre with tarmac.

Work out the total cost of the tarmac Bill needs.

$$\text{Area of } \textcircled{1} : 40 \times 60 = 2400 \text{ m}^2$$

$$\text{Area of } \textcircled{2} : \left( \frac{60 + 30}{2} \right) \times 40 = 1800 \text{ m}^2$$

$$\text{Total Area} = 4200 \text{ m}^2$$

$$\begin{aligned} \text{Cost} &= 4200 \times 2.56 \\ &= \text{£}10752 \end{aligned}$$

£.....10752.....

(Total for Question 8 is 4 marks)



9

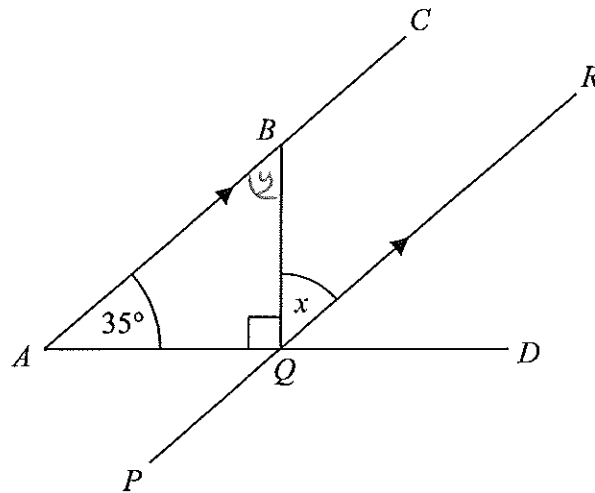

Diagram NOT  
accurately drawn

$ABC$ ,  $PQR$  and  $AQD$  are straight lines.  
 $ABC$  is parallel to  $PQR$ .

Angle  $BAQ = 35^\circ$

Angle  $BQA = 90^\circ$

Work out the size of the angle marked  $x$ .  
Give reasons for each stage of your working.

Angle  $ABQ = 55^\circ$  (angles in a triangle  
add to  $180^\circ$ ) ✓

Angle  $BQR (x) = 55^\circ$  (alternate angles are  
equal) ✓

$x = \dots\dots\dots^\circ$

(Total for Question 9 is 4 marks)



10 The equation

$$x^3 + 2x = 110$$

has a solution between 4 and 5

Use a trial and improvement method to find this solution.

Give your answer correct to one decimal place.

You must show ALL your working.

$x$	$x^3 + 2x$	
4.5	100.125	(small)
4.7	113.223	(big)
4.6	106.536	(small) ✓

Between 4.6 & 4.7

4.65      109.846...      (small) ✓

4.6      4.65      4.7

$x = 4.7$  (1dp) ✓

(Total for Question 10 is 4 marks)



11 XYZ is a right-angled triangle.

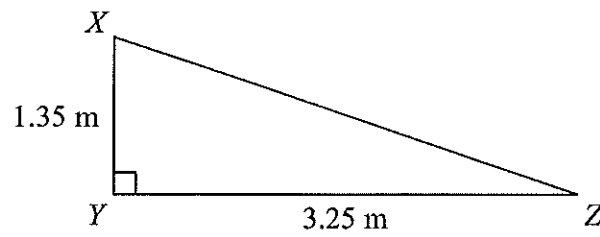

Diagram NOT  
accurately drawn

Calculate the length of XZ.  
Give your answer correct to 3 significant figures.

$$\begin{aligned} XZ &= \sqrt{1.35^2 + 3.25^2} \\ &= \sqrt{12.385} \\ &= 3.519232\dots \end{aligned}$$

3.52  
..... m

(Total for Question 11 is 3 marks)



12 (a) Solve  $3(x-2) = x+7$

$$\begin{array}{r} 3x - 6 = x + 7 \\ -x \quad \left\{ \begin{array}{l} 2x - 6 = 7 \\ +6 \quad \left\{ \begin{array}{l} 2x = 13 \\ \div 2 \quad \left\{ \begin{array}{l} x = 6.5 \end{array} \right. \end{array} \right. \end{array} \right. \end{array}$$

$x = \frac{6.5}{(3)}$

(b) Solve  $\frac{2-y}{5} = 1$

$$\begin{array}{r} \times 5 \quad \left\{ \begin{array}{l} 2 - y = 5 \\ +y \quad \left\{ \begin{array}{l} 2 = 5 + y \\ -5 \quad \left\{ \begin{array}{l} -3 = y \end{array} \right. \end{array} \right. \end{array} \right. \end{array}$$

$y = \frac{-3}{(2)}$

(Total for Question 12 is 5 marks)



13

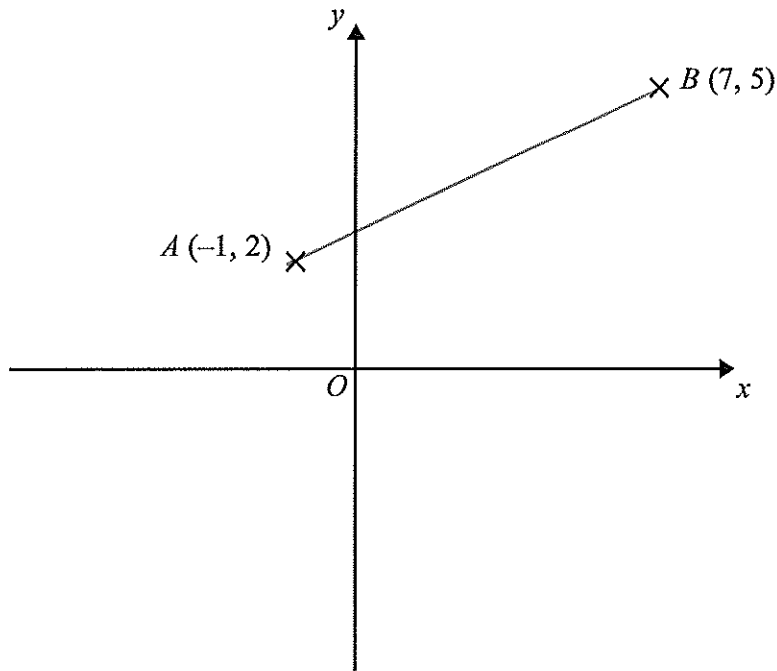

Diagram NOT accurately drawn

A is the point (-1, 2)  
B is the point (7, 5)

(a) Find the coordinates of the midpoint of AB.

(x)  $\frac{-1 + 7}{2} = 3$

(y)  $\frac{2 + 5}{2} = 3.5$

(3, 3.5)  
(2)

P is the point (-4, 4)  
Q is the point (1, -5)

(b) Find the gradient of PQ.

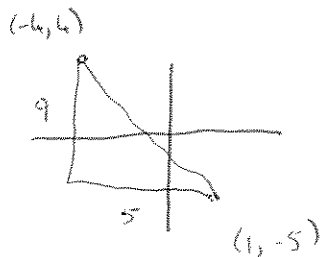

Gradient =  $-\frac{9}{5} = -1.8$

(-1.8)  
(2)

(Total for Question 13 is 4 marks)



\*14 Viv wants to invest £2000 for 2 years in the same bank.

**The International Bank**

Compound Interest

4% for the first year

1% for each extra year

**The Friendly Bank**

Compound Interest

5% for the first year

0.5% for each extra year

At the end of 2 years, Viv wants to have as much money as possible.

Which bank should she invest her £2000 in?

International

$$\begin{aligned} \text{Year 1: } & 2000 \times 1.04 \\ & = \pounds 2080 \end{aligned}$$

$$\begin{aligned} \text{Year 2: } & 2080 \times 1.01 \\ & = \pounds 2100.80 \end{aligned}$$

Friendly

$$\begin{aligned} \text{Year 1: } & 2000 \times 1.05 \\ & = \pounds 2100 \end{aligned}$$

$$\begin{aligned} \text{Year 2: } & 2100 \times 1.005 \\ & = \pounds 2110.50 \end{aligned}$$

She should choose

~~International bank~~

Friendly Bank to get  $\pounds 2110.50$   
as opposed to  $\pounds 2100.80$

(Total for Question 14 is 4 marks)





15 (a) Complete the table of values for  $y = x^2 - 2x$

x	-2	-1	0	1	2	3	4
y	8	3	0	-1	0	3	8

(2)

(b) On the grid, draw the graph of  $y = x^2 - 2x$  for values of  $x$  from -2 to 4

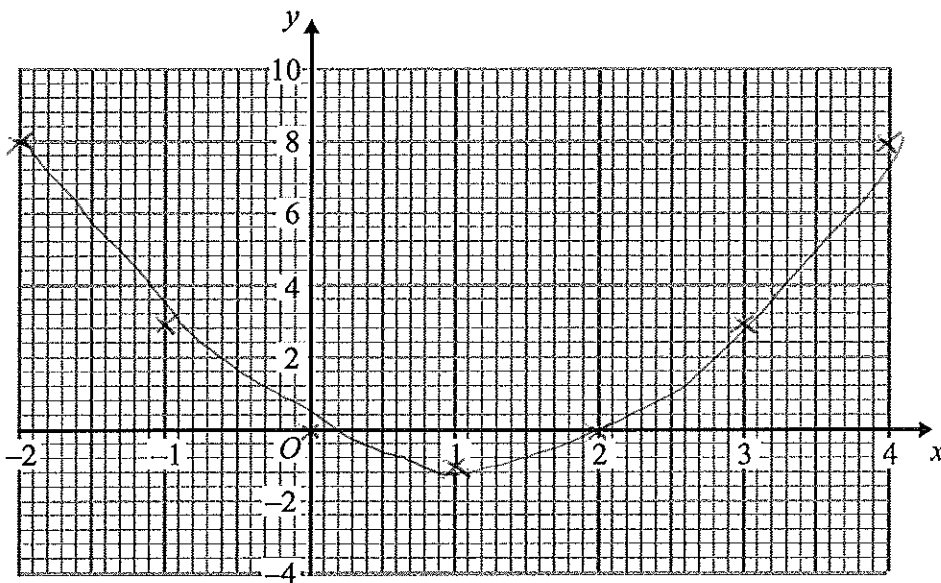

(2)

(c) Solve  $x^2 - 2x - 2 = 1$

$$x^2 - 2x - 3 = 0$$

$$(x - 3)(x + 1) = 0$$

$$x - 3 = 0$$

$$\rightarrow x = 3$$

$$x + 1 = 0$$

$$x = -1$$

(2)

(Total for Question 15 is 6 marks)



P 4 3 6 0 0 A 0 1 7 2 8

\*16

Diagram NOT  
accurately drawn

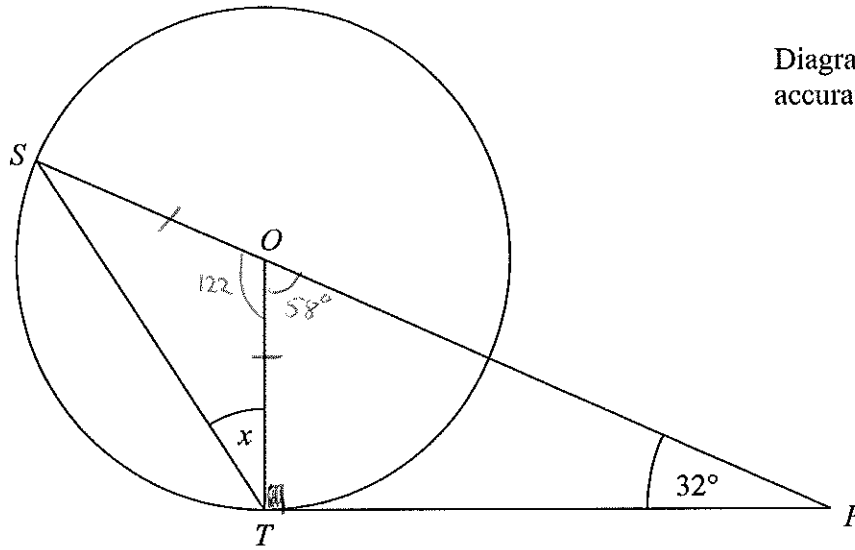

$S$  and  $T$  are points on the circumference of a circle, centre  $O$ .  
 $PT$  is a tangent to the circle.  
 $SOP$  is a straight line.

Angle  $OPT = 32^\circ$

Work out the size of the angle marked  $x$ .  
Give reasons for your answer.

$$OTP = 90^\circ \quad (\text{tangent/radius})$$

$$POT = 58^\circ \quad (\text{angles in a triangle add up to } 180^\circ)$$

$$\overset{SOT}{\cancel{OPT}} = 122^\circ \quad (\text{angles on a straight line add to } 180^\circ)$$

$$x = \frac{180 - 122}{2} = 29^\circ \quad (\text{angles in an ISOSCELES triangle add to } 180^\circ)$$

..... 29 °

(Total for Question 16 is 5 marks)



17 Some girls did a sponsored swim to raise money for charity.

The table shows information about the amounts of money (£) the girls raised.

Least amount of money (£)	10
Greatest amount of money (£)	45
Median	25
Lower quartile	16
Upper quartile	42

(a) On the grid, draw a box plot for the information in the table.

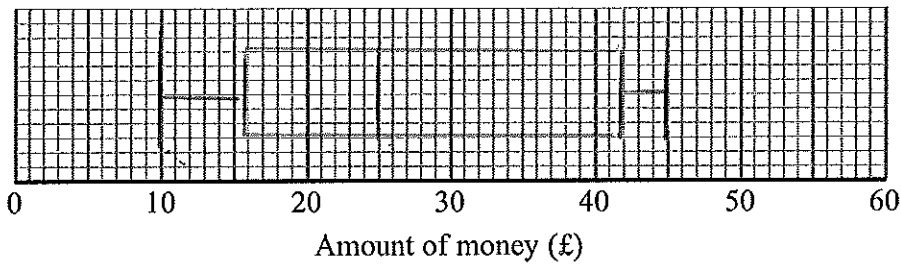

(2)

Some boys also did the sponsored swim.

The box plot shows information about the amounts of money (£) the boys raised.

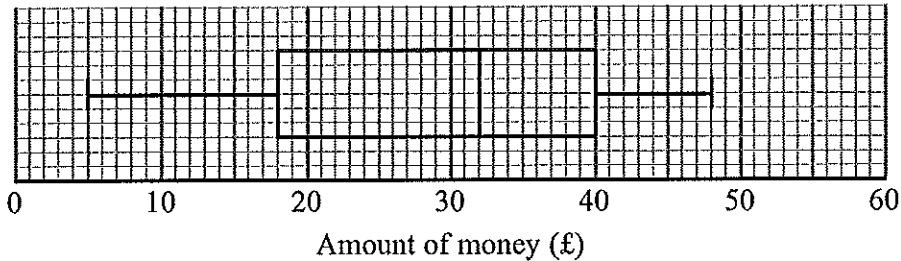

(b) Compare the amounts of money the girls raised with the amounts of money the boys raised.

① On average the boys raised more as their median is greater (£32 compared to £25) ✓

② The boys were more consistent in the money they raised as their Inter-quartile Range was smaller (22 compared to 26) ✓ (2)

(Total for Question 17 is 4 marks)



18 Make  $p$  the subject of the formula

$$y = 3p^2 - 4$$

$$\begin{aligned} +4 & \left\{ \begin{aligned} y + 4 &= 3p^2 \\ \div 3 & \frac{y + 4}{3} = p^2 \\ \sqrt{\phantom{x}} & \sqrt{\frac{y + 4}{3}} = p \end{aligned} \right. \end{aligned}$$

$$p = \sqrt{\frac{y + 4}{3}}$$

(Total for Question 18 is 3 marks)

19 (a) Factorise  $6 + 9x$

$$3(2 + 3x)$$

(1)

(b) Factorise  $y^2 - 16$

$$(y + 4)(y - 4)$$

(1)

(c) Factorise  $2p^2 - p - 10$

~~(2p + 5)(p + 2)~~  
 $(2p - 5)(p + 2)$

(2)

(Total for Question 19 is 4 marks)



7

\*20 The diagram shows a ladder leaning against a vertical wall.

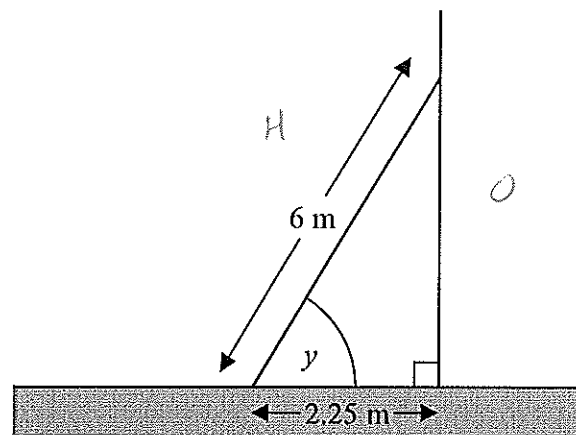

Diagram NOT accurately drawn

The ladder stands on horizontal ground.

The length of the ladder is 6 m.

The bottom of the ladder is 2.25 m from the bottom of the wall.

A ladder is safe to use when the angle marked  $y$  is about  $75^\circ$ .

Is the ladder safe to use?

You must show all your working.

trig  
$$\cos \theta = \frac{\text{Adj}}{\text{Hyp}}$$

$$\cos(y) = \frac{2.25}{6} \quad \checkmark$$

$$y = \cos^{-1}\left(\frac{2.25}{6}\right) = 67.9756...^\circ \quad \checkmark$$

Ladder not safe as angle is  $68^\circ$  which is not close to  $75^\circ$  ✓

(Total for Question 20 is 3 marks)



P 4 3 6 0 0 A 0 2 1 2 8

21 In Holborn School there are

460 students in Key Stage 3

320 students in Key Stage 4

165 students in Key Stage 5

Nimer is carrying out a survey.

He needs a sample of 100 students stratified by Key Stage.

Work out the number of students from Key Stage 3 there should be in the sample.

$$\text{Total students} = 945$$

$$\text{Key Stage 3} = \frac{460}{945} \times 100$$

$$= 48.677\dots$$

49 students

(Total for Question 21 is 2 marks)

22  $h$  is inversely proportional to the square of  $r$ .

When  $r = 5$ ,  $h = 3.4$

Find the value of  $h$  when  $r = 8$

$$h \propto \frac{1}{r^2}$$

$$h = \frac{k}{r^2}$$

$$3.4 = \frac{k}{5^2}$$

$$\times 5^2 \quad \left\{ \begin{array}{l} 5^2 \times 3.4 = k = 85 \end{array} \right.$$

$$h = \frac{85}{r^2}$$

$$h = \frac{85}{8^2}$$

$$= \frac{85}{64}$$

or

$$h = 1.328125$$

(Total for Question 22 is 3 marks)



23 Dan does an experiment to find the value of  $\pi$ .  
 He measures the circumference and the diameter of a circle.

He measures the circumference,  $C$ , as 170 mm to the nearest millimetre.  
 He measures the diameter,  $d$ , as 54 mm to the nearest millimetre.

Dan uses  $\pi = \frac{C}{d}$  to find the value of  $\pi$ .

Calculate the upper bound and the lower bound for Dan's value of  $\pi$ .

$$\begin{aligned} \text{upper bound} &= \frac{\text{MAX}}{\text{MIN}} \\ &= \frac{170.5}{53.5} = 3.1869\dots \end{aligned}$$

$$\begin{aligned} \text{lower} &= \frac{\text{MIN}}{\text{MAX}} \\ &= \frac{169.5}{54.5} = 3.11009\dots \end{aligned}$$

upper bound = 3.187

lower bound = 3.110

(Total for Question 23 is 4 marks)



4

24  $ABC$  is a triangle.

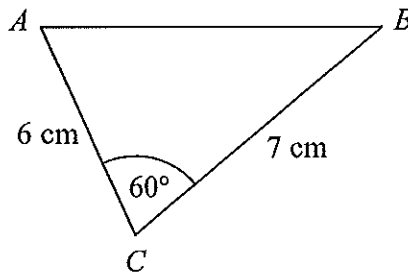

Diagram NOT accurately drawn

- (a) Work out the area of triangle  $ABC$ .  
Give your answer correct to 3 significant figures.

$$\begin{aligned} \text{Area} &= \frac{1}{2} ab \sin(c) \\ &= \frac{1}{2} \times 6 \times 7 \times \sin(60) \\ &= 18.18653... \\ &= 18.2 \text{ cm}^2 \end{aligned}$$

(2)

- (b) Work out the length of the side  $AB$ .  
Give your answer correct to 3 significant figures.

$$\begin{aligned} c^2 &= a^2 + b^2 - 2ab \cos(c) \\ c^2 &= 6^2 + 7^2 - 2 \times 6 \times 7 \times \cos(60) \\ c^2 &= 43 \\ c &= \sqrt{43} = 6.55743... \\ &= 6.56 \text{ cm} \end{aligned}$$

(3)

(Total for Question 24 is 5 marks)



S



25 Solve the simultaneous equations  $x^2 + y^2 = 9$   
 $x + y = 2$

Give your answers correct to 2 decimal places.

$$x + y = 2$$

$$-x \left\{ \begin{array}{l} y = 2 - x \end{array} \right.$$

Sub into:  $x^2 + y^2 = 9$

$$x^2 + (2-x)^2 = 9$$

$$x^2 + 4 - 4x + x^2 = 9$$

$$2x^2 - 4x + 4 = 9$$

$$2x^2 - 4x - 5 = 0$$

$$(2-x)(2-x)$$

$$4 - 2x - 2x + x^2$$

$$x^2 - 4x + 4$$

use formula:

$$x = \frac{4 \pm \sqrt{(-4)^2 - 4 \times 2 \times (-5)}}{2 \times 2}$$

$$x = \frac{4 \pm \sqrt{56}}{4} = 2.8708... \text{ or } -0.8708...$$

Find y by:  $y = 2 - x$

$$y = 2 - 2.8708 = -0.8708$$

or

$$x = 2.87 \quad y = -0.87$$

$$y = 2 - (-0.8708) = 2.8708$$

$$\text{or } x = -0.87 \quad y = 2.87$$

(Total for Question 25 is 6 marks)

TOTAL FOR PAPER IS 100 MARKS

