

Write your name here

Surname

Other names

Centre Number

Candidate Number

Edexcel GCSE

Mathematics A

Paper 1 (Non-Calculator)

Higher Tier

Tuesday 11 June 2013 – Morning
Time: 1 hour 45 minutes

Paper Reference
1MA0/1H

You must have: Ruler graduated in centimetres and millimetres, protractor, pair of compasses, pen, HB pencil, eraser. Tracing paper may be used.

Total Marks

Instructions

- Use **black** ink or ball-point pen.
- **Fill in the boxes** at the top of this page with your name, centre number and candidate number.
- Answer **all** questions.
- Answer the questions in the spaces provided – *there may be more space than you need.*
- **Calculators must not be used.**



Information

- The total mark for this paper is 100
- The marks for **each** question are shown in brackets – *use this as a guide as to how much time to spend on each question.*
- Questions labelled with an **asterisk (*)** are ones where the quality of your written communication will be assessed.

Advice

- Read each question carefully before you start to answer it.
- Keep an eye on the time.
- Try to answer every question.
- Check your answers if you have time at the end.

Turn over ►

P43598A

©2013 Pearson Education Ltd.

6/5/5/



PEARSON

GCSE Mathematics 1MA0

Formulae: Higher Tier

You must not write on this formulae page.
Anything you write on this formulae page will gain NO credit.

Volume of prism = area of cross section \times length

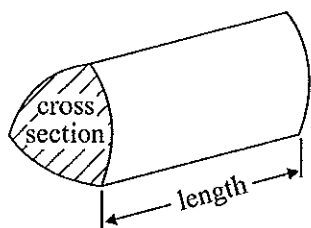

Area of trapezium = $\frac{1}{2} (a + b)h$

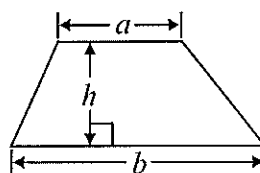

Volume of sphere = $\frac{4}{3}\pi r^3$

Surface area of sphere = $4\pi r^2$

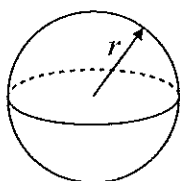

Volume of cone = $\frac{1}{3}\pi r^2 h$

Curved surface area of cone = $\pi r l$

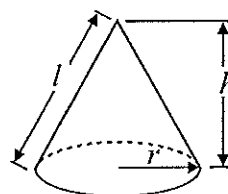

In any triangle ABC

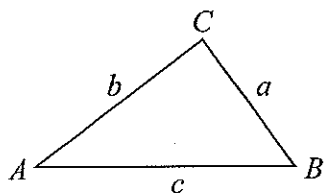

The Quadratic Equation

The solutions of $ax^2 + bx + c = 0$
where $a \neq 0$, are given by

$$x = \frac{-b \pm \sqrt{b^2 - 4ac}}{2a}$$

Sine Rule $\frac{a}{\sin A} = \frac{b}{\sin B} = \frac{c}{\sin C}$

Cosine Rule $a^2 = b^2 + c^2 - 2bc \cos A$

Area of triangle = $\frac{1}{2} ab \sin C$



Answer ALL questions.

Write your answers in the spaces provided.

You must write down all stages in your working.

You must NOT use a calculator.

1 Given that $1793 \times 185 = 331\,705$

write down the value of

(a) 1.793×185

$331\,705$

331.705

(b) $331\,705 \div 1.85$

$1793 \times 100 = 179300$

179300

(Total for Question 1 is 2 marks)

2 Mr Mason asks 240 Year 11 students what they want to do next year.

15% of the students want to go to college.

$\frac{3}{4}$ of the students want to stay at school.

The rest of the students do not know.

Work out the number of students who do not know.

$15\% \text{ of } 240 = 36$

$10\% = 24$

$5\% = 12$

$240 \div 4 = 60$

$60 \times 3 = 180$

$36 + 180 = 216$

$240 - 216 = 24$

24

(Total for Question 2 is 4 marks)



3 Sixteen babies are born in a hospital.

Here are the weights of the babies in kilograms.

2.4 2.7 3.5 4.4 4.5 4.1 4.4 2.8
4.1 3.8 3.8 4.2 3.3 3.0 3.7 3.3

Show this information in an ordered stem and leaf diagram.

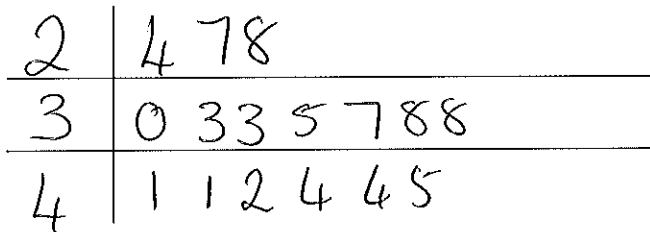
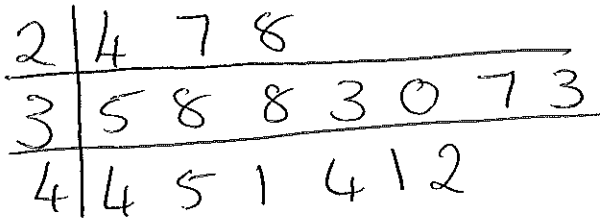

Key:

$$2|4 = 2.4$$

(Total for Question 3 is 3 marks)

4 (a) Expand $3(2 + t)$

$$3(2 + t) \quad 6 + 3t$$

$$\frac{6 + 3t}{(1)}$$

(b) Expand $3x(2x + 5)$

$$3x(2x + 5) \quad 6x^2 + 15x$$

$$\frac{6x^2 + 15x}{(2)}$$

(c) Expand and simplify $(m + 3)(m + 10)$

$$(m + 3)(m + 10)$$

$$m^2 + 10m + 3m + 30$$

$$\frac{m^2 + 13m + 30}{(2)}$$

(Total for Question 4 is 5 marks)



5 Write 525 as a product of its prime factors.

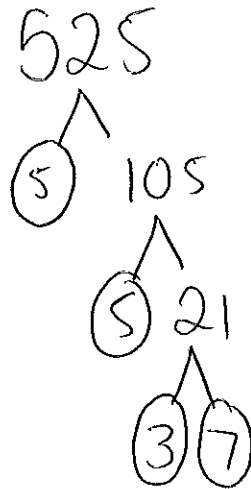

$$3 \times 5 \times 5 \times 7$$

or

$$3 \times 5^2 \times 7$$

$$3 \times 5^2 \times 7$$

(Total for Question 5 is 3 marks)

6 Ed has 4 cards.
There is a number on each card.

12

6

15

?

The mean of the 4 numbers on Ed's cards is 10

Work out the number on the 4th card.

$$4 \times 10 = 40$$

$$12 + 6 + 15 = 33$$

$$40 - 33 = 7$$

7

(Total for Question 6 is 3 marks)



P 4 3 5 9 8 A 0 5 2 8

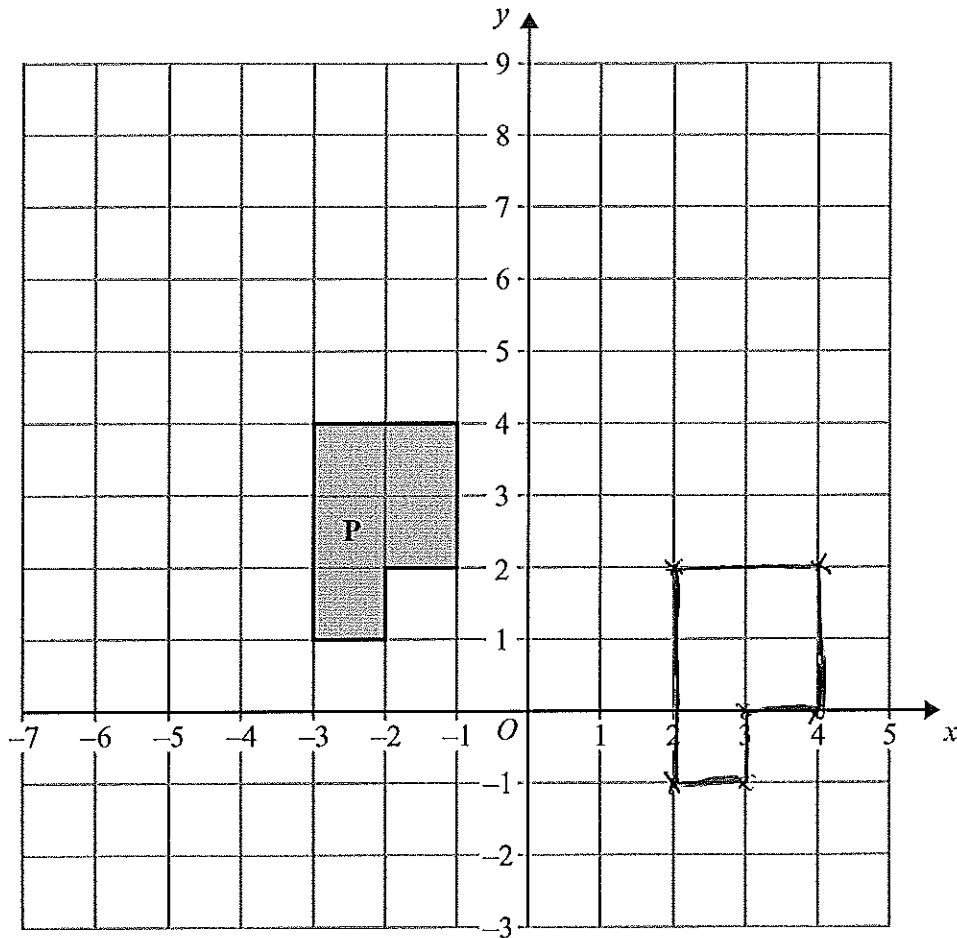

(a) Translate shape **P** by the vector $\begin{pmatrix} 5 \\ -2 \end{pmatrix}$

(2)

5 to the right
2 down



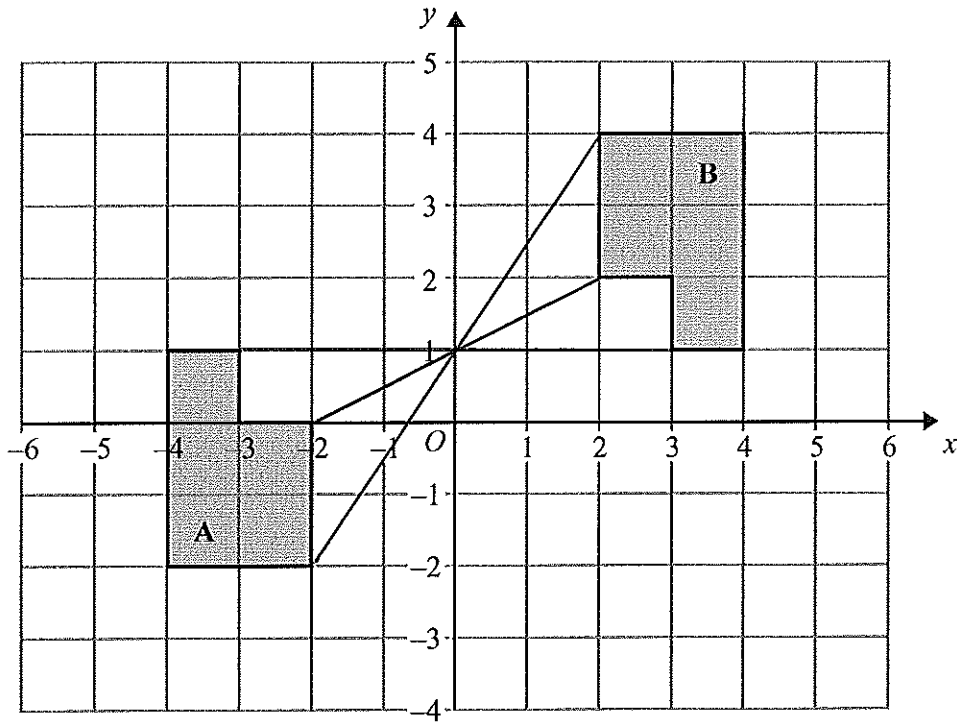

(b) Describe fully the single transformation that maps shape A onto shape B.

Rotation of 180° with centre of
enlargement $(0, 1)$

(3)

(Total for Question 7 is 5 marks)



P 4 3 5 9 8 A 0 7 2 8

- 8 Margaret has some goats.
 The goats produce an average total of 21.7 litres of milk per day for 280 days.
 Margaret sells the milk in $\frac{1}{2}$ litre bottles.

Work out an estimate for the total number of bottles that Margaret will be able to fill with the milk.

You must show clearly how you got your estimate.

$$21.7 \text{ l} \approx 20$$

$$280 \text{ days} \approx 300$$

$$\frac{20 \times 300}{0.5} = \frac{6000}{0.5} = 12000$$

12,000.....

(Total for Question 8 is 3 marks)

- 9 Matt and Dan cycle around a cycle track.

Each lap Matt cycles takes him 50 seconds.

Each lap Dan cycles takes him 80 seconds.

Dan and Matt start cycling at the same time at the start line.

Work out how many laps they will each have cycled when they are next at the start line together.

Matt	Dan
50	80
100	160
150	240
200	320
250	400
300	
350	
400	

Matt.....8..... laps

Dan.....5..... laps

(Total for Question 9 is 3 marks)



10 The diagram shows a garden in the shape of a rectangle.

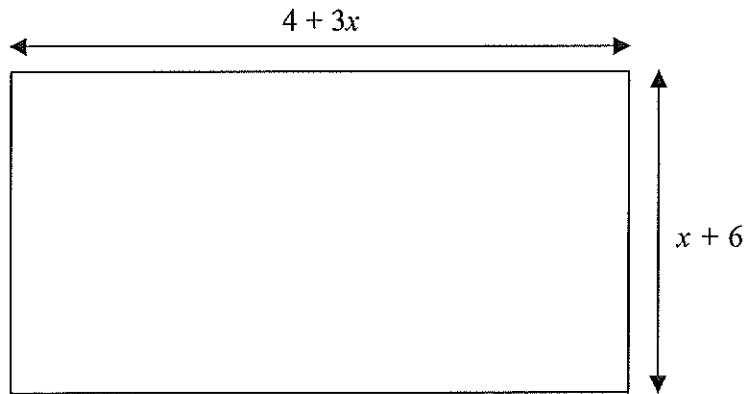

All measurements are in metres.
The perimeter of the garden is 32 metres.

Work out the value of x

$$4 + 3x + x + 6 + 4 + 3x + x + 6$$

$$\begin{array}{l} -20 \\ \hline \div 8 \end{array} \left| \begin{array}{l} 8x + 20 = 32\text{m} \\ 8x = 12\text{m} \\ x = 1.5 \end{array} \right.$$

1.5

(Total for Question 10 is 4 marks)



P 4 3 5 9 8 A 0 9 2 8

*11 Debbie drove from Junction 12 to Junction 13 on a motorway.

The travel graph shows Debbie's journey.

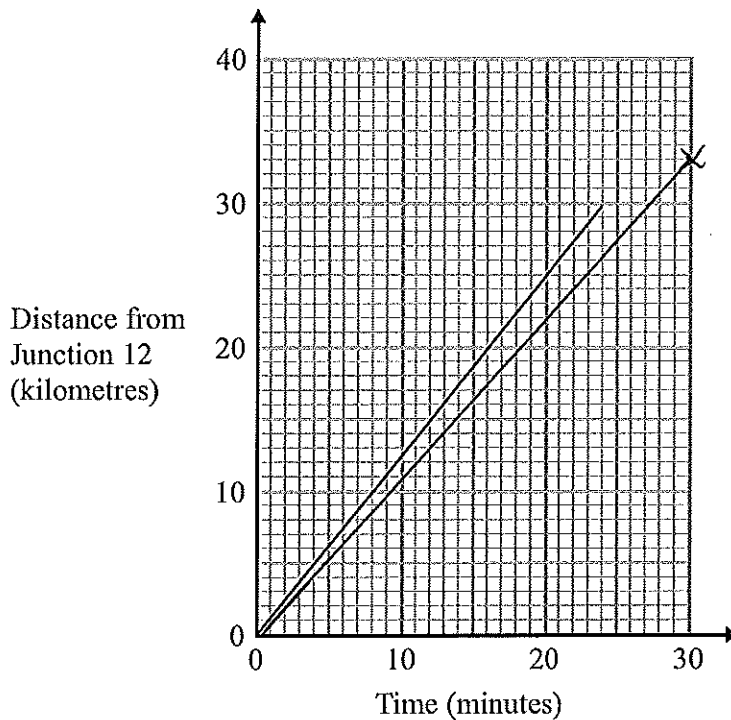

Ian also drove from Junction 12 to Junction 13 on the same motorway.
He drove at an average speed of 66 km/hour.

Who had the faster average speed, Debbie or Ian?
You must explain your answer.

$66 \text{ km/hour} = 33 \text{ km per half hour.}$
Debbie has a faster average speed as
the gradient of her graph is steeper than
Ian's.
Also she was 20 km away from the
junction quicker than Ian.

(Total for Question 11 is 4 marks)



12 On the grid, draw the graph of $y = \frac{1}{2}x + 5$ for values of x from -2 to 4

x	-2	-1	0	1	2	3	4
y	4	4.5	5	5.5	6	6.5	7

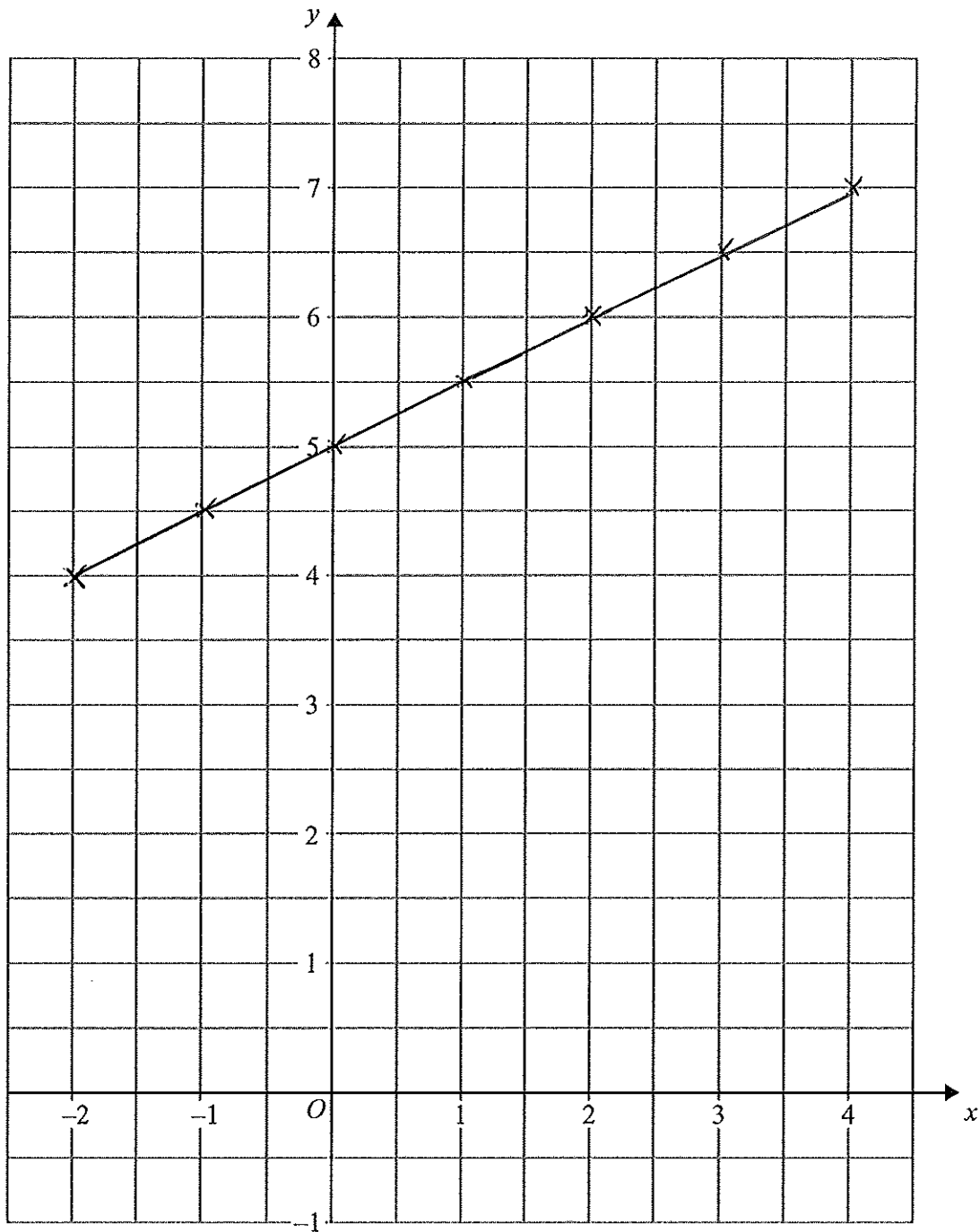

(Total for Question 12 is 3 marks)



P 4 3 5 9 8 A 0 1 1 2 8

- *13 Here is a map.
The position of a ship, S , is marked on the map.

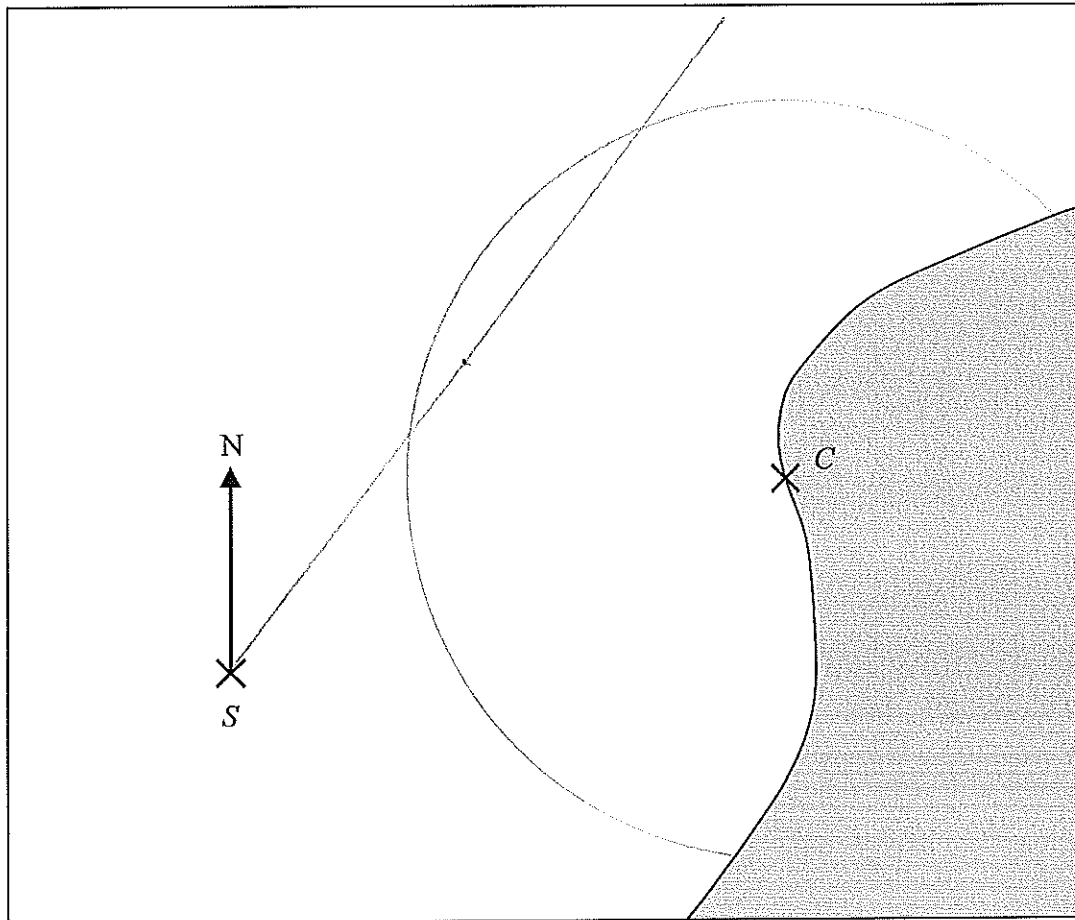

Scale 1 cm represents 100 m

Point C is on the coast.
Ships must not sail closer than 500 m to point C .

The ship sails on a bearing of 037°

Will the ship sail closer than 500 m to point C ?
You must explain your answer.

Yes it will as the bearing crosses into the region that is within 500m of C

(Total for Question 13 is 3 marks)



14 $-2 < n \leq 3$

(a) Represent this inequality on the number line.

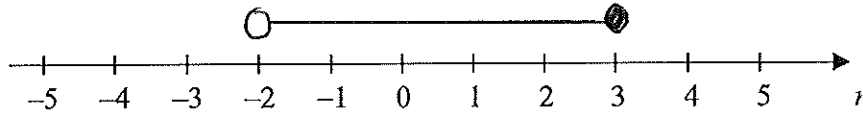

○ is for when it doesn't equal that number
● is when it does equal that number. (2)

(b) Solve the inequality $8x - 3 \geq 6x + 4$

$$\begin{array}{l|l} & 8x - 3 \geq 6x + 4 \\ -6x & 2x - 3 \geq 4 \\ +3 & 2x \geq 7 \\ \div 2 & x \geq 3.5 \end{array}$$

$$x \geq 3.5$$

(2)

(Total for Question 14 is 4 marks)

*15 One sheet of paper is 9×10^{-3} cm thick.

Mark wants to put 500 sheets of paper into the paper tray of his printer.
The paper tray is 4 cm deep.

Is the paper tray deep enough for 500 sheets of paper?
You must explain your answer.

$$9 \times 10^{-3} = 0.009$$

$$0.009 \times 500 = 4.5 \text{ cm}$$

The tray is not deep enough as the 500 sheets of paper has a depth of 4.5 cm and the tray is smaller than that.

(Total for Question 15 is 3 marks)



16 The normal price of a television is reduced by 30% in a sale.

The sale price of the television is £350

Work out the normal price of the television.

$$\begin{array}{l} \div 7 \left(\begin{array}{l} \text{£}350 = 70\% \\ \text{£}50 = 10\% \\ \text{£}500 = 100\% \end{array} \right) \div 7 \\ \times 10 \left(\begin{array}{l} \text{£}350 = 70\% \\ \text{£}50 = 10\% \\ \text{£}500 = 100\% \end{array} \right) \times 10 \end{array}$$

£.....500.....

(Total for Question 16 is 3 marks)



17 Sumeet has a pond in the shape of a prism.

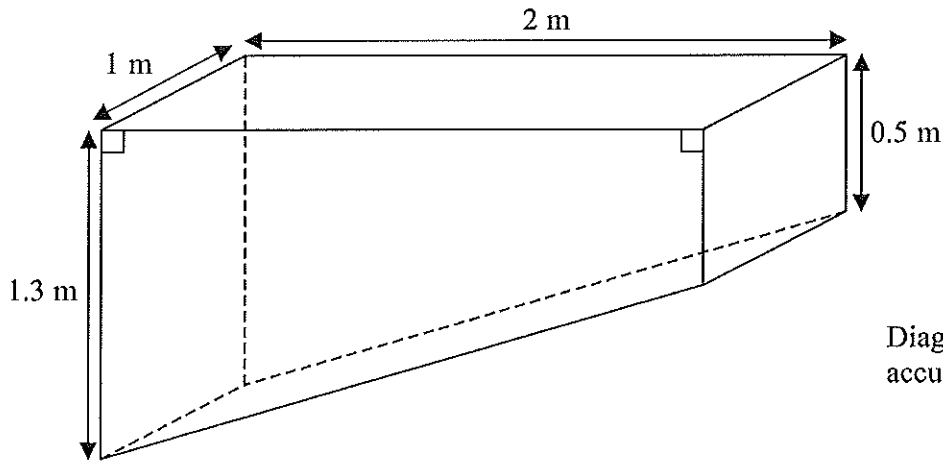

Diagram NOT accurately drawn

The pond is completely full of water.
Sumeet wants to empty the pond so he can clean it.
Sumeet uses a pump to empty the pond.

The volume of water in the pond decreases at a constant rate.
The level of the water in the pond goes down by 20 cm in the first 30 minutes.

Work out how much more time Sumeet has to wait for the pump to empty the pond completely.

Volume of pool

$$\left(\frac{0.5 + 1.3}{2}\right) \times 2 = 1.8 \text{ m}^2$$

$$1.8 \times 1 = 1.8 \text{ m}^3$$

$$1 \times 2 \times 0.2 = 0.4 \text{ m}^3$$

$$0.4 \text{ m}^3 = 30 \text{ mins}$$

$$1.8 - 0.4 = 1.4 \text{ m}^3 \text{ left}$$

$$1.4 \div 0.4 = 3.5$$

$$3.5 \times 30 = 105 \text{ mins}$$

$$105 \text{ mins} = 1 \text{ hr } 45 \text{ mins}$$

1 hr 45 mins

(Total for Question 17 is 6 marks)



P 4 3 5 9 8 A 0 1 5 2 8

18 Solve the simultaneous equations

$$\begin{aligned} \textcircled{1} & 4x + 7y = 1 \\ \textcircled{2} & 3x + 10y = 15 \end{aligned}$$

$$\begin{aligned} \textcircled{1} \times 3 &= 12x + 21y = 3 \\ \textcircled{2} \times 4 &= 12x + 40y = 60 \end{aligned}$$

$$\begin{aligned} \textcircled{2} - \textcircled{1} & \\ 12x + 40y &= 60 \\ 12x + 21y &= 3 \\ \hline 19y &= 57 \end{aligned}$$

$$y = 3$$

Substitute y into $\textcircled{1}$

$$4x + (7 \times 3) = 1$$

$$4x + 21 = 1$$

$$4x = -20$$

$$x = -5$$

$$x = \underline{-5}$$

$$y = \underline{3}$$

(Total for Question 18 is 4 marks)

19 Write these numbers in order of size.
Start with the smallest number.

$$\begin{aligned} 5^{-1} &= \frac{1}{5} = 0.2 \\ 5^0 &= 1 \end{aligned}$$

$$\underline{-5, 5^{-1}, 0.5, 5^0}$$

(Total for Question 19 is 2 marks)



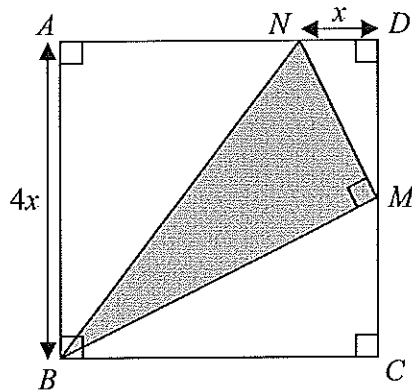

Diagram NOT
accurately drawn

$ABCD$ is a square with a side length of $4x$
 M is the midpoint of DC .
 N is the point on AD where $ND = x$

BMN is a right-angled triangle.

Find an expression, in terms of x , for the area of triangle BMN .
 Give your expression in its simplest form.

Area of square

$$4x \times 4x = 16x^2$$

Area of triangle ABN

$$\frac{4x \times 3x}{2} = 6x^2$$

Area of triangle MDN

$$\frac{2x \times x}{2} = x^2$$

Area of triangle BCM

$$\frac{4x \times 2x}{2} = 4x^2$$

Add together the triangles

$$6x^2 + x^2 + 4x^2 = 11x^2$$

$$16x^2 - 11x^2 = 5x^2$$

$$5x^2$$

(Total for Question 20 is 4 marks)



21 The table below shows information about the heights of 60 students.

Height (x cm)	Number of students
$140 < x \leq 150$	4
$150 < x \leq 160$	5
$160 < x \leq 170$	16
$170 < x \leq 180$	27
$180 < x \leq 190$	5
$190 < x \leq 200$	3

Cf
4
9
25
52
57
60

(a) On the grid opposite, draw a cumulative frequency graph for the information in the table.

(3)



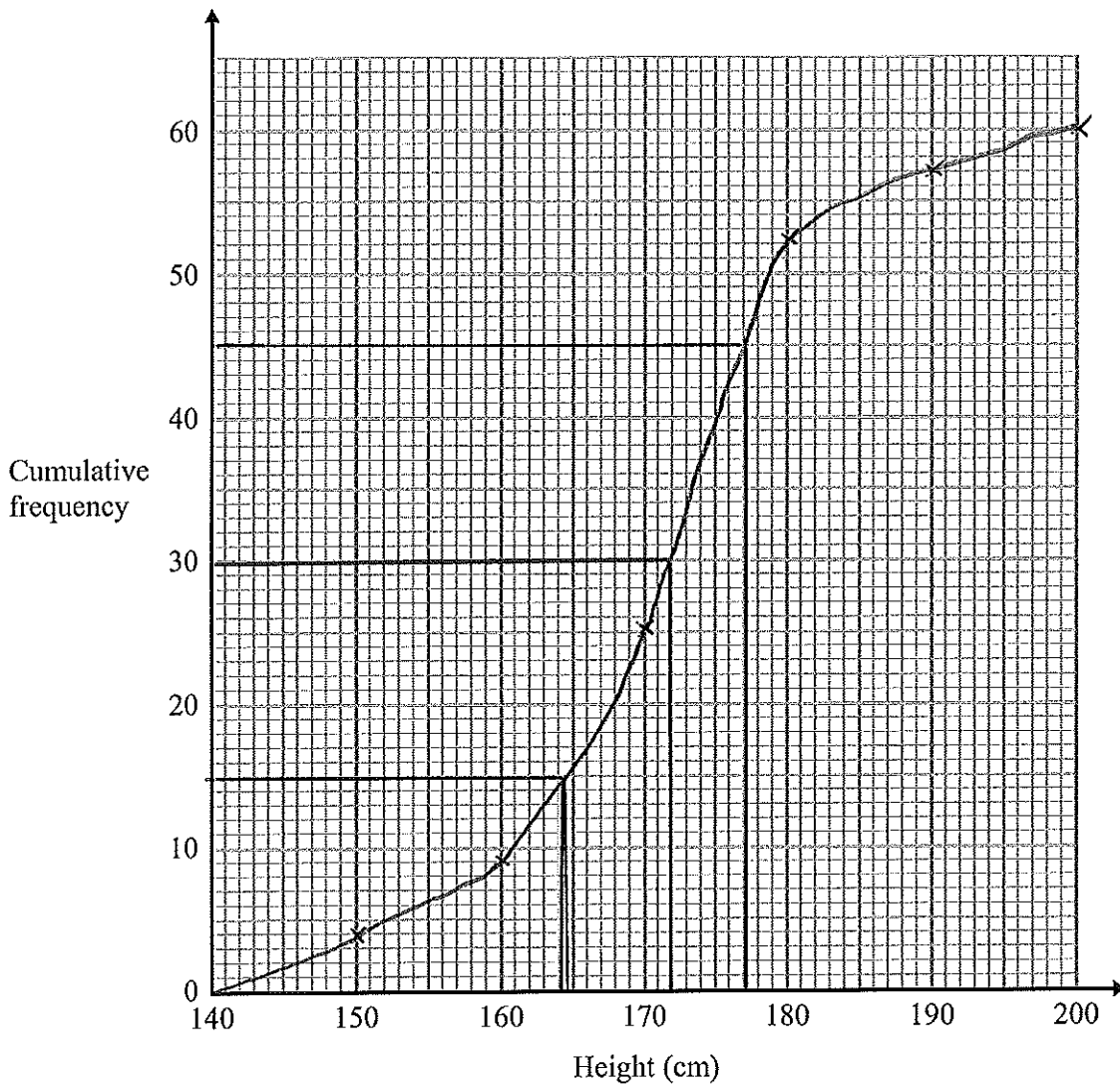

(b) Find an estimate

(i) for the median,

$$60 \div 2 = 30$$

172 cm

(ii) for the interquartile range.

$$177 - 164 = 13$$

13 cm
(3)

(Total for Question 21 is 6 marks)



22 P and Q are two triangular prisms that are mathematically similar.

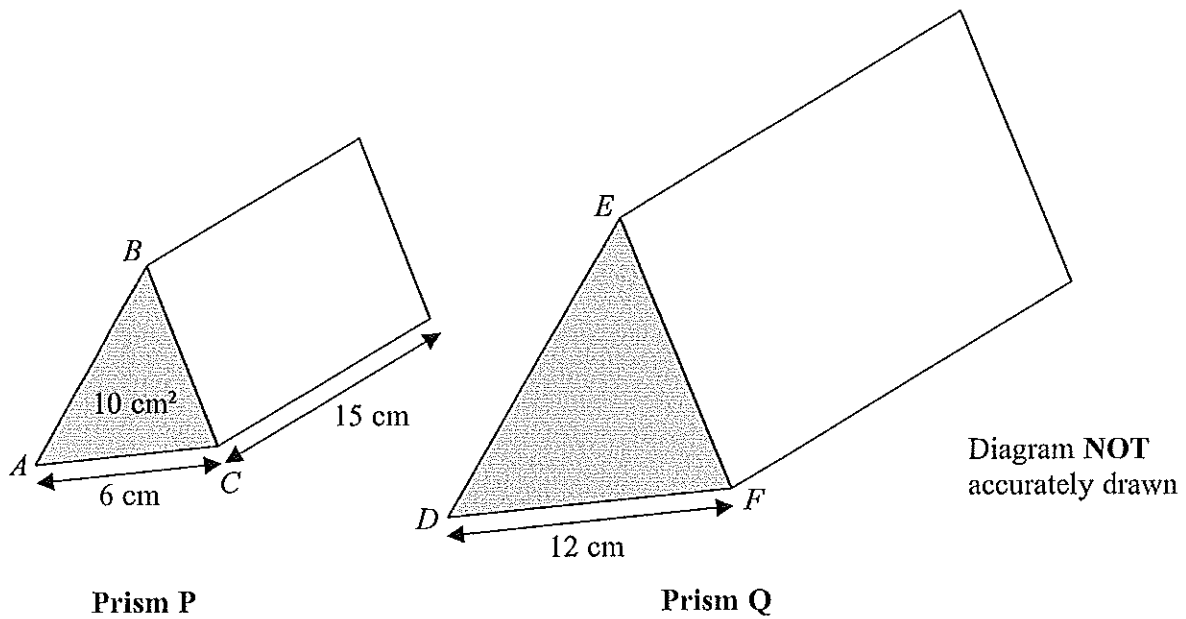

Prism P has triangle ABC as its cross section.
Prism Q has triangle DEF as its cross section.

$$AC = 6 \text{ cm}$$

$$DF = 12 \text{ cm}$$

The area of the cross section of prism P is 10 cm^2 .
The length of prism P is 15 cm.

Work out the volume of prism Q.

Scale factor

$$12 \div 6 = 2$$

Area of Q

$$10 \text{ cm}^2 \times 2^2 = 40 \text{ cm}^2$$

Length of Q = $15 \times 2 = 30$

Volume of Q

$$30 \times 40 = 1200$$

$$1200 \text{ cm}^3$$

(Total for Question 22 is 4 marks)



23 Simplify $\frac{4(x+5)}{x^2+2x-15}$

$$\frac{4(x+5)}{(x+5)(x-3)}$$

$$\frac{4}{x-3}$$

$$\frac{4}{x-3}$$

(Total for Question 23 is 2 marks)



24 Bill works for a computer service centre.

The table shows some information about the length of time, t minutes, of the phone calls Bill had.

Time (t minutes)	$0 < t \leq 10$	$10 < t \leq 15$	$15 < t \leq 20$	$20 < t \leq 30$	$30 < t \leq 45$
Number of calls	12	15	13	18	3

fd $12 \div 10 = 1.2$ $15 \div 5 = 3$ $13 \div 5 = 2.6$ $18 \div 10 = 1.8$ $3 \div 3 = 1$

On the grid, draw a histogram to show this information.

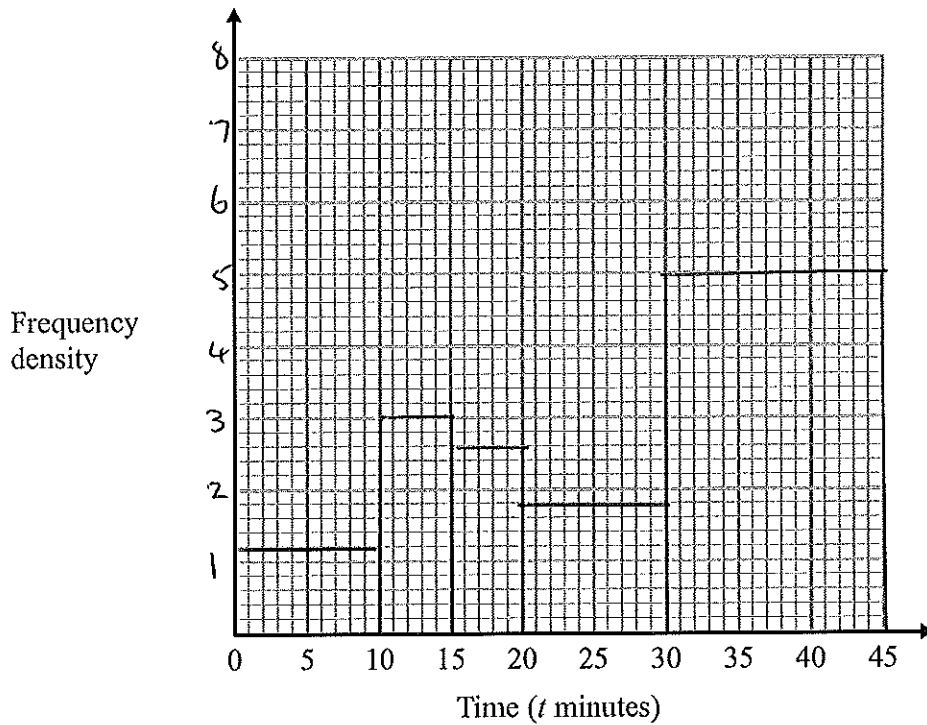

(Total for Question 24 is 3 marks)



26 Fiza has 10 coins in a bag.
There are three £1 coins and seven 50 pence coins.

Fiza takes at random, 3 coins from the bag.

Work out the probability that she takes exactly £2.50

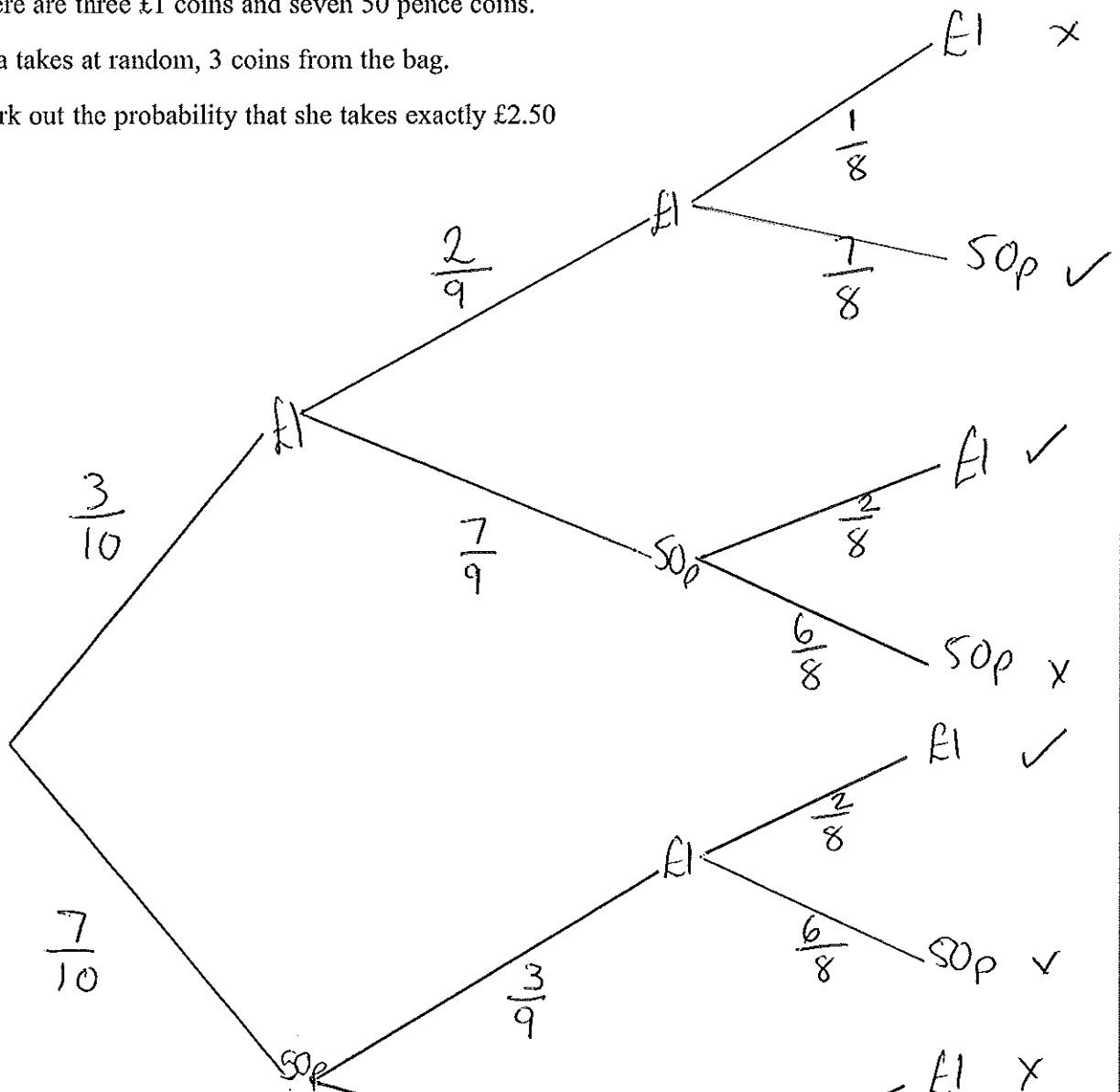

$$\frac{3}{10} \times \frac{2}{9} \times \frac{7}{8} = \frac{42}{720}$$

$$+ \frac{6}{9}$$

$$\frac{3}{10} \times \frac{7}{9} \times \frac{2}{8} = \frac{42}{720}$$

$$+ \frac{42}{720}$$

$$\frac{7}{10} \times \frac{3}{9} \times \frac{2}{8} = \frac{42}{720}$$

$$= \frac{126}{720} = \frac{63}{360} = \frac{21}{120} = \frac{7}{40}$$

(Total for Question 26 is 4 marks)



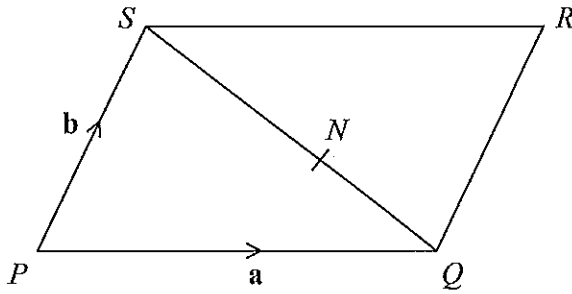

Diagram NOT
accurately drawn

$PQRS$ is a parallelogram.

N is the point on SQ such that $SN : NQ = 3 : 2$

$$\vec{PQ} = \mathbf{a}$$

$$\vec{PS} = \mathbf{b}$$

(a) Write down, in terms of \mathbf{a} and \mathbf{b} , an expression for \vec{SQ} .

$$\vec{SP} = -\mathbf{b}$$

$$\vec{PQ} = +\mathbf{a}$$

$$\vec{SQ} = \mathbf{a} - \mathbf{b} \quad (1)$$

(b) Express \vec{NR} in terms of \mathbf{a} and \mathbf{b} .

$$\vec{SR} = \mathbf{a}$$

$$\vec{QR} = \mathbf{b}$$

$$\vec{NQ} = \frac{2}{5}(\mathbf{a} - \mathbf{b})$$

$$\frac{2}{5}\mathbf{a} - \frac{2}{5}\mathbf{b} + \mathbf{b} = \frac{2}{5}\mathbf{a} + \frac{3}{5}\mathbf{b}$$

$$\vec{NR} = \frac{2}{5}\mathbf{a} + \frac{3}{5}\mathbf{b} \quad (3)$$

(Total for Question 27 is 4 marks)



28 The diagram shows a sketch of the graph of $y = \cos x^\circ$

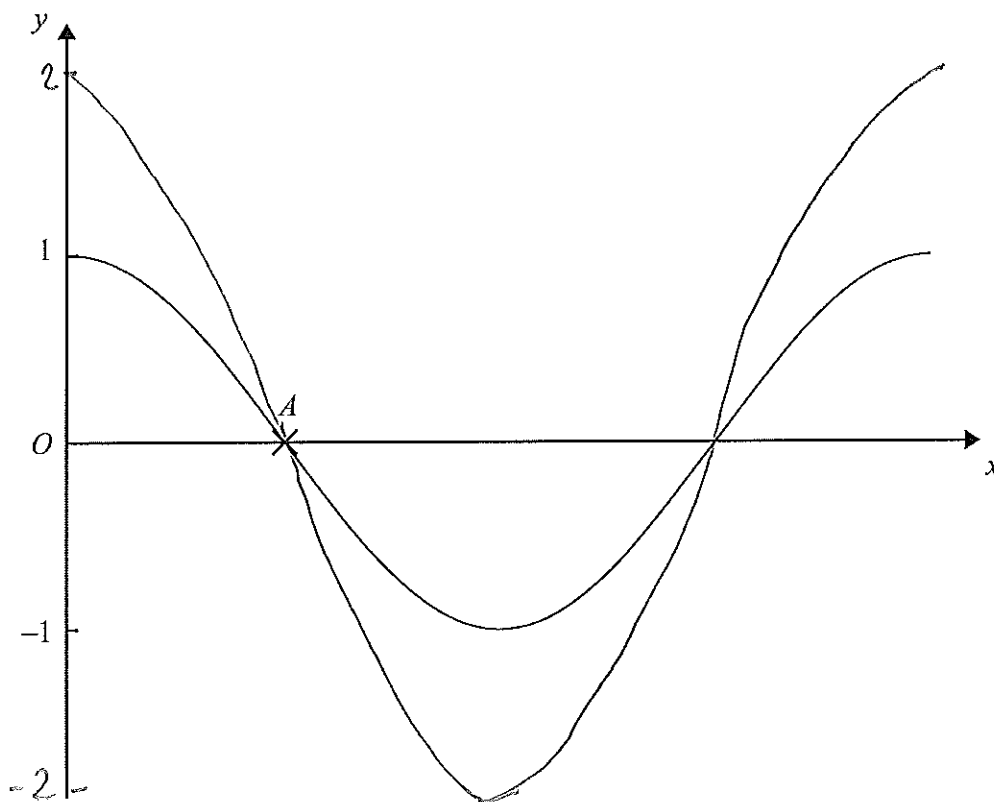

(a) Write down the coordinates of the point A .

(90, 0)
(1)

(b) On the same diagram, draw a sketch of the graph of $y = 2 \cos x^\circ$

(1)

(Total for Question 28 is 2 marks)

TOTAL FOR PAPER IS 100 MARKS



BLANK PAGE



P 4 3 5 9 8 A 0 2 7 2 8

BLANK PAGE

